



SERIES B

POWER TRANSMISSION
SOLUTIONS

Precision. Motion Control. Technology.



Cone Drive is a world leader in precision motion control technology.

We work with our customers every step of the way - from design specs to the final solution - to create highly precise, highly specific products that keep our customers' technology at the forefront of their industry. Cone Drive offers engineering support, unique solutions, and innovative technology across a breadth of markets and products to drive your company forward.



TABLE OF CONTENTS

SERIES B

Introduction.....	5
Unit Designation	11
Output Shaft Option	12
Output Bore Options	13
Motor Adaptors NEMA	14
Mounting Positions	15
Double Reduction Primary Unit Mounting Positions	17
Additional Gear Unit Features	18
Explanation & Use of Ratings & Service Factors	19
Load Classification by Application	20
Selection Procedure Motor Ready Units.....	21
DIMENSIONS	23
Dimensions - Single Reduction Units	24
Dimensions - Double Reduction Units	29
Customer Shaft Dimensions	35
Torque Arm Details	36
DIMENSIONAL COMPARISON.....	37
Dimension Interchangeability	38
RATINGS	44
Ratings - Single Reduction 1150 RPM	45
Ratings - Double Reduction 1150 RPM	46
Ratings - Single Reduction 1750 RPM.....	47
Ratings - Double Reduction 1750 RPM.....	48
KIT SELECTION	49
GearHead Kits	50
NEMA Motor Adaptor Kits	51
Input Shaft Kits	51
Shaft & Base Kits.....	52
Shaft Mount Bushing Kit	53
Output Bracket & Torque Arm Mount Kits.....	54
Double Reduction Units - Mounting Kits	55
Installation, Operation & Maintenance Instructions	56
Product Safety Information	57



Serving an entire spectrum of mechanical drive applications from food, energy, mining and metal; to automotive, aerospace and marine propulsion, we are your source for gearbox solutions.

INDUSTRIAL SOLUTIONS

SERIES HP

Worm gearbox with double-enveloping worm gearing. Available in single, double and triple reductions



SERIES HP-A

Universal metric housing featuring double-enveloping gearing & drywell feature



SERIES B

Industrial duty worm gearbox featuring Conex gearing



DUO DRIVE

Dual gears on parallel output shafts



SLEW SOLUTIONS

Versatile slew bearings and slew drives featuring external, internal and without teeth options in a low profile, ready-to-install package



STAINLESS

Right angle, IP-69K rated for the food processing market



DOUBLE-ENVELOPING WORM GEAR SET

Available in standard sizes, ratios and backlash options along with custom worm gear sets.



PRECISION MOTION SOLUTIONS

SERIES W

Precision right angle servo gearbox



SERIES RC

Moderate precision right angle servo gearbox



SERIES S

Value engineered right angle servo gearbox

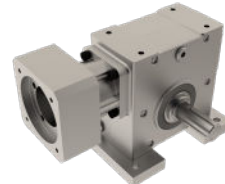

SERIES LE / P

In-line helical geared motors & reducers and precision planetary servo gearbox



HARMONIC

Cone Drive Harmonic Solutions® offer the ultimate in precision motion control technology



STAINLESS SERVO

Smooth, contoured stainless steel housing (316), IP69K rated right angle gearbox



HP SERVO

This double-enveloping worm gearing, high torque gearbox meets the most demanding needs as servo motor capacities increase



We can create custom engineered transmission solutions of any size and configuration.

GEARBOXES

The Series B right angle gearboxes provide a highly flexible and compact solution to meet the low to medium power range. With power capabilities up to 20 HP and a maximum output torque capacity of 7,500 lb-in, we can provide design flexibility with lasting performance.

The Series B benefits from Cone Drive's extensive history and experience in the design and manufacture of high quality mechanical power transmission solutions. With features like our non-fretting motor connection and the unique **Swift Kit** concept. Series B is the answer for your right angle gearbox requirements.

- Conex™ helicoidal gear geometry provides high capacity and high efficiency.

- Motor connection eliminates fretting corrosion and provides easy motor removal.

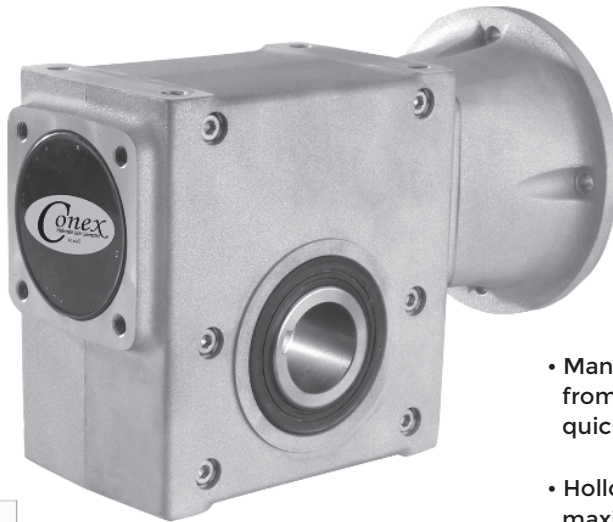

Visit ConeTools.com to configure 3D models and specification sheets

ConeTools.com

- Manufactured and assembled from a family of modular kits for quick delivery.
- Hollow bore standard for maximum flexibility.
- Dimensionally interchangeable with other major manufacturers.

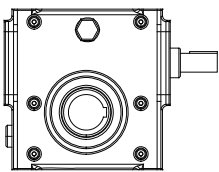

Standard Single Unit

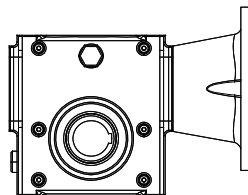

Motor Ready Unit

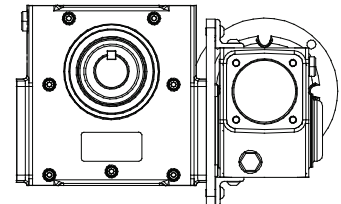

Double Reduction Unit

Configure Your Accudrive Online

www.ConeTools.com

The screenshot shows a web browser window displaying the Cone Drive website. The browser's address bar shows "conetools.com". The website header includes the Cone Drive logo and navigation links for "Cone Drive", "Cone Tools", and "Contact". The main content area features a large image of a Series B gearbox with a "CONFIGURE" button. Below this is a descriptive paragraph: "The Cone Drive Series B is an economical, flexible and compact solution designed to meet low-medium power range requirements. With capabilities up to 5,000 in-lbs in a single stage the Series B provides the performance and reliability that you have come to expect from Cone Drive." Below the main content is a section titled "Industrial & Food Processing" with four product cards: "Series B", "Model RG", "Model HP", and "Series HP-A". Each card includes an image, a "CONFIGURE" button, and a brief description. A fifth card for "Stainless Steel" is also visible below the others.

Series B
A flexible and economical industrial right angle gearbox solution.

Model RG
A moderate precision, high torque capacity servo or NEMA interfacing right angle gearbox solution.

Model HP
A right angle gearbox solution with the highest torque and shock load ratings in it's class.

Series HP-A
A right angle gearbox solution with universal mounting options and optional drywell feature.

Stainless Steel
A right angle, IP69K rated stainless gearbox solution



Visit ConeTools.com
and Click "Series B"

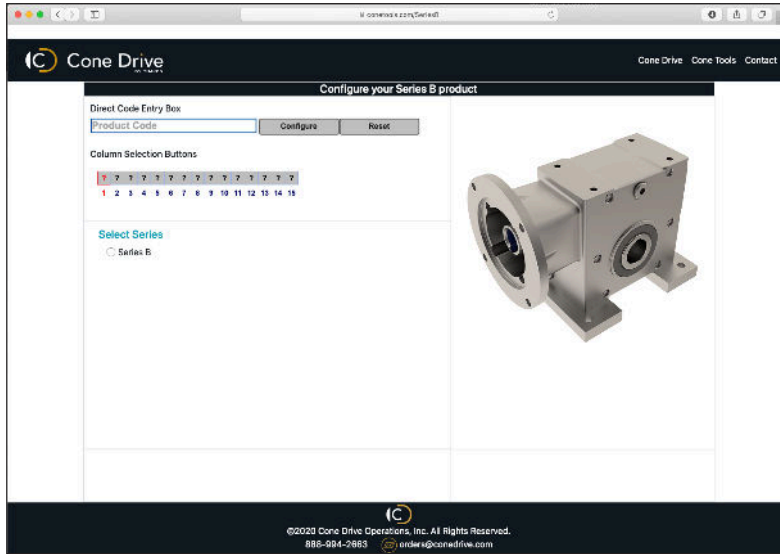

2
Select a product or enter in the Direct Code and click Configure

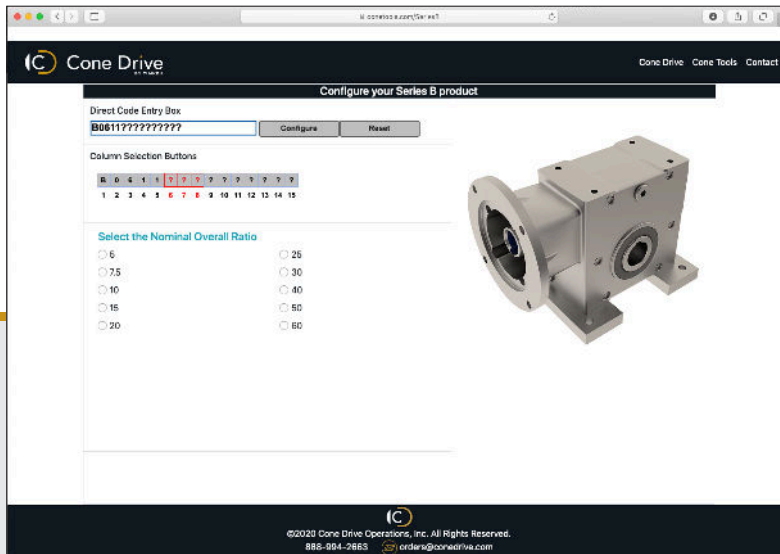

3
Select Motor Information and proceed to additional selections

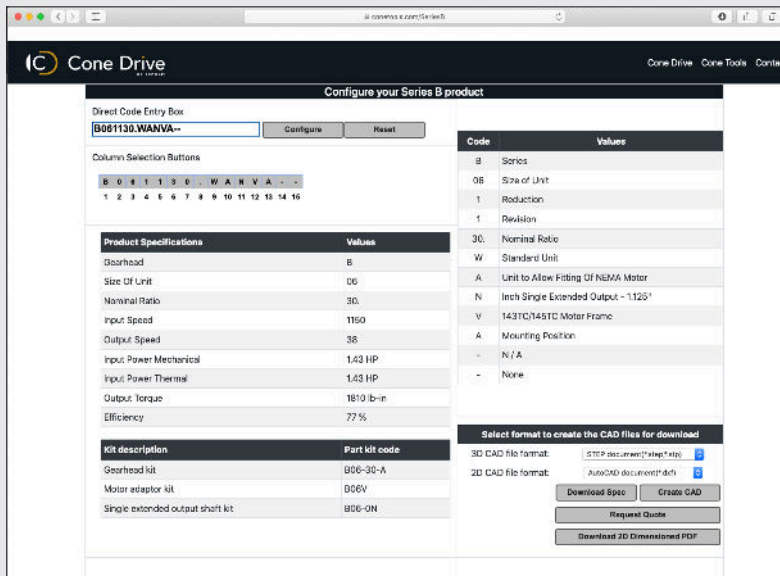

4
On final screen download the specifications or request a quote and drawing

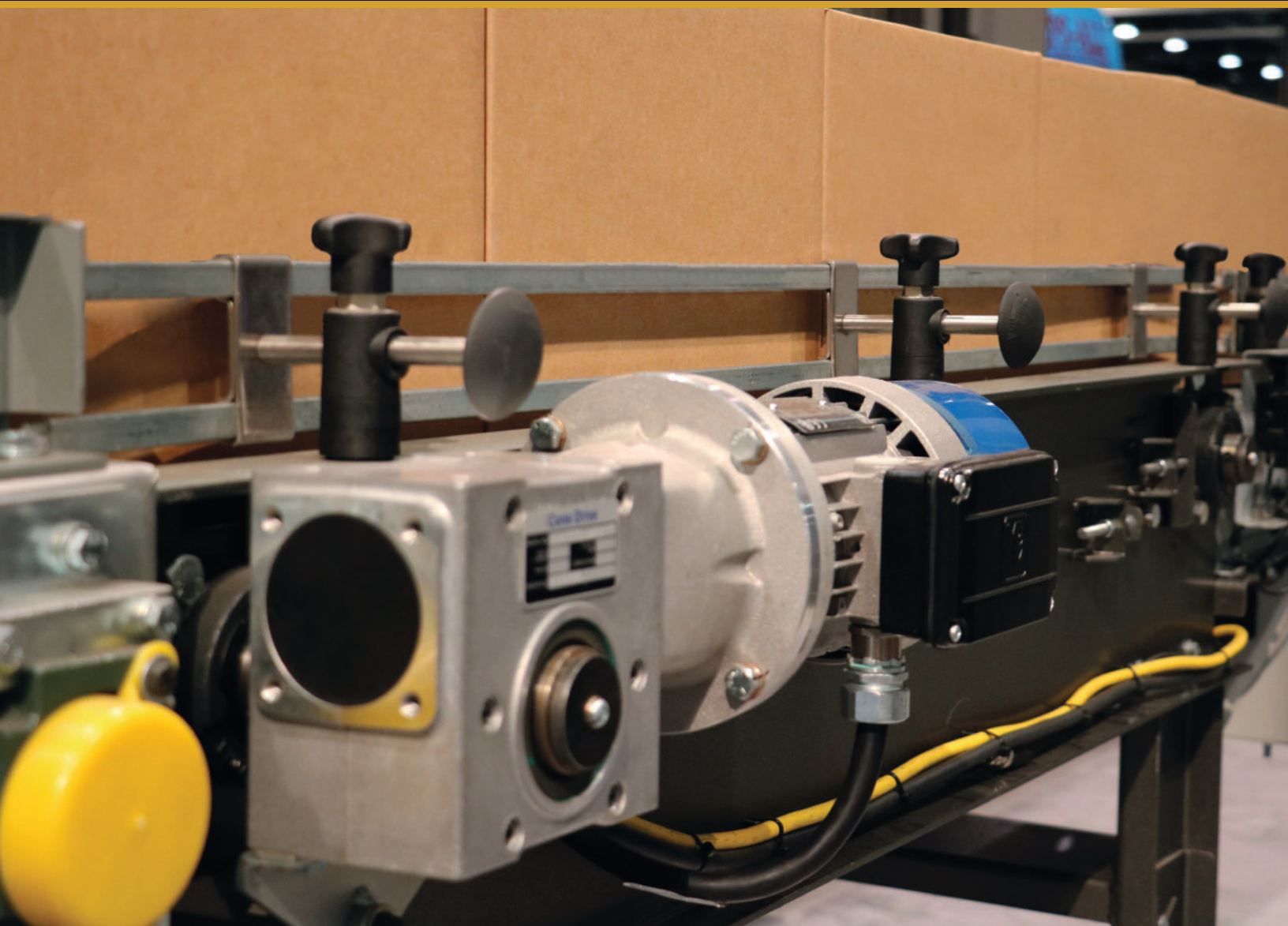

PACKAGING | STEEL | PLASTICS & RUBBER | CONVEYOR | PULP & PAPER

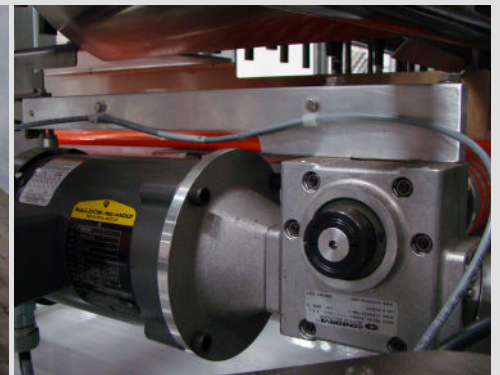
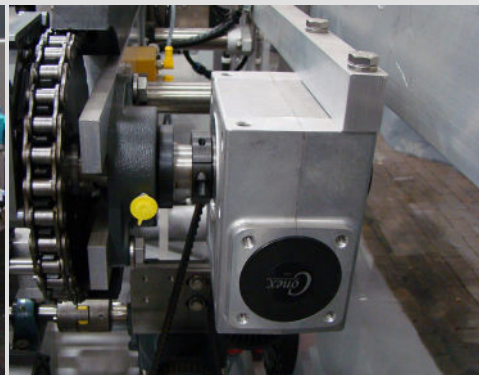
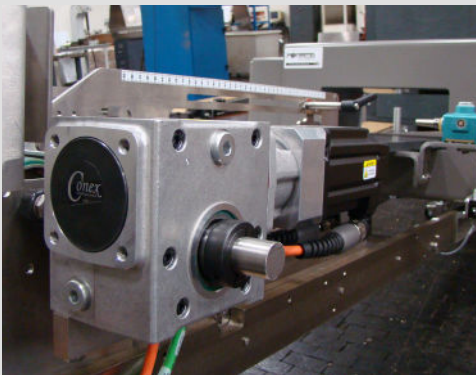



AN ECONOMIC SOLUTION THAT PACKS A PUNCH.

Cone Drive's Series B gearboxes provide an economical, flexible, and compact solution to fulfill the low-to-medium power range requirements. With capabilities up to 20HP and output torque up to 8,000 lb. in. Series B can provide design flexibility with lasting performance.

Right Angle Gearbox

Directly interchangeable with most worm reducers, this right angle gearbox is unlike any other reducer on the market. No other reducer offers the flexibility, performance, and reliability that you have come to expect from Cone Drive.

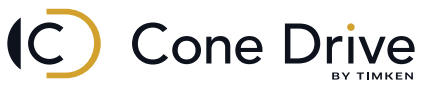
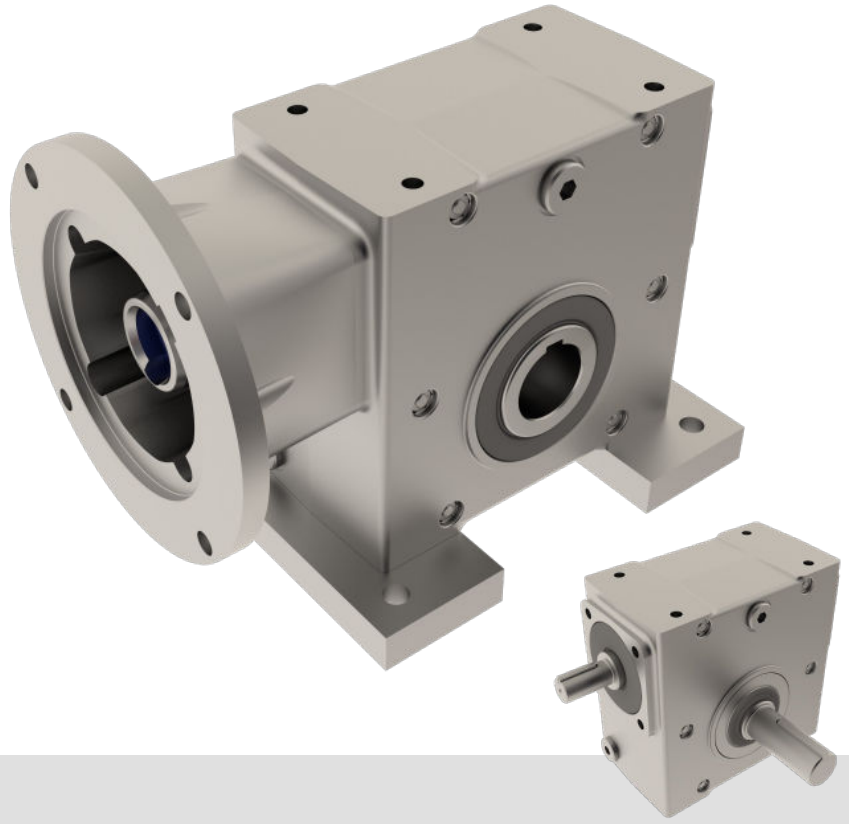

S P E C I F I C A T I O N S

PRODUCT FEATURES

- Complete motor mounting accessories
- Easy motor removal with fret-free motor bushing
- Dimensionally interchangeable with other manufacturers
- Lightweight aluminum construction
- Conex double enveloping gearing

PRODUCT SPECIFICATIONS

- Center Distance:** 1.33" - 3.54"
- Output Torque:** Up to 7,500 lb-in
- Gear Ratios:** Up to 3600:1 in double reduction
- Input Options:** Reducer and NEMA
- Output Options:** Solid or hollow, metric and inch
- Washdown Options:** USDA white epoxy paint, SS fasteners and output shafts

SERIES B

Series B right angle gearboxes provide a very compact solution to meet the demands of today's industrial gearbox requirements. Our over 70 years of experience in design and manufacturing has resulted in a range of right angle products offering high load carrying capacity, high efficiency, quiet running and reliability with lasting performance.

Single & Double Reduction Units

Series B is offered in unit sizes 02, 03, 04, 05, 06, 08, 09, 10 and 11 based on a single universal gear case for each size, giving a high degree of common parts and interchangeability. Units can be mounted in all mounting positions and provide a choice of shaft arrangements for either motor ready or reducer versions. Motors can be close coupled via a motor connection system offering power coverage up to 20 HP.

All units are designed with hollow output shaft as standard, solid output shafts can be fitted allowing hand of assembly to be changed without dismantling the unit. Double extended output shafts are also available.

Series B offers a choice of 10 standard ratios from 5/1 to 60/1 in Single Reduction units and 15 standard ratios from 100/1 to 3600/1 in Double Reduction units. All units are lubricated for life to reduce maintenance to a minimum.

Motor Ready Units with Engineered Motor Connection System

Units are designed to be close coupled with standard dimension NEMA frame motors. The motor connection system eliminates fretting corrosion allowing the easy removal of motors from the gearbox to minimize down time and maintenance time.

Lubricated for Life

Series B units are factory filled with high quality synthetic lubricant which means:

- The product arrives ready for use
- No oil level checks, topping up, draining or re-filling
- No danger of starting up without lubricant
- Mount in any location, however inaccessible

Sealed and Non-Vented

Series B units are sealed against the environment and operate without the need to be vented. This allows the product to be shipped factory filled yet doesn't require vents to be retrofitted in the correct position prior to operation. It also offers protection against the ingress of contaminants in the field and eliminates a leak path.

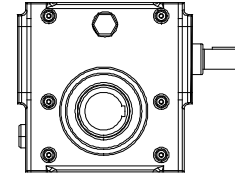

Standard Single Reduction Units

B	0	5	1	1	1	5	-	W	R	A	-	1	-	-
---	---	---	---	---	---	---	---	---	---	---	---	---	---	---

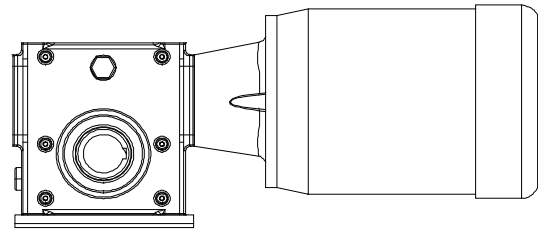

Motor Ready Units with Horizontal Base

B	0	4	1	1	2	0	.	B	A	A	T	1	-	1
---	---	---	---	---	---	---	---	---	---	---	---	---	---	---

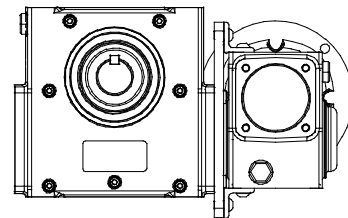

Motor Ready Double Reduction Unit

B	0	4	2	1	2	0	.	W	A	A	T	1	1	-
---	---	---	---	---	---	---	---	---	---	---	---	---	---	---

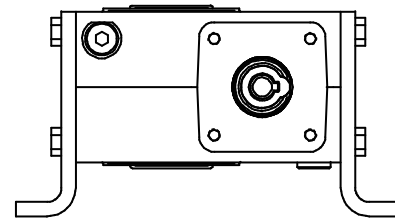

Units with Vertical Base

B	0	8	1	1	3	0	.	L	R	A	-	A	-	-
---	---	---	---	---	---	---	---	---	---	---	---	---	---	---

* Typical unit designations.

As improvements in design are being made continually this specification is not to be regarded as binding in detail and drawings and capacities are subject to alteration without notice. Certified drawings will be sent on request.

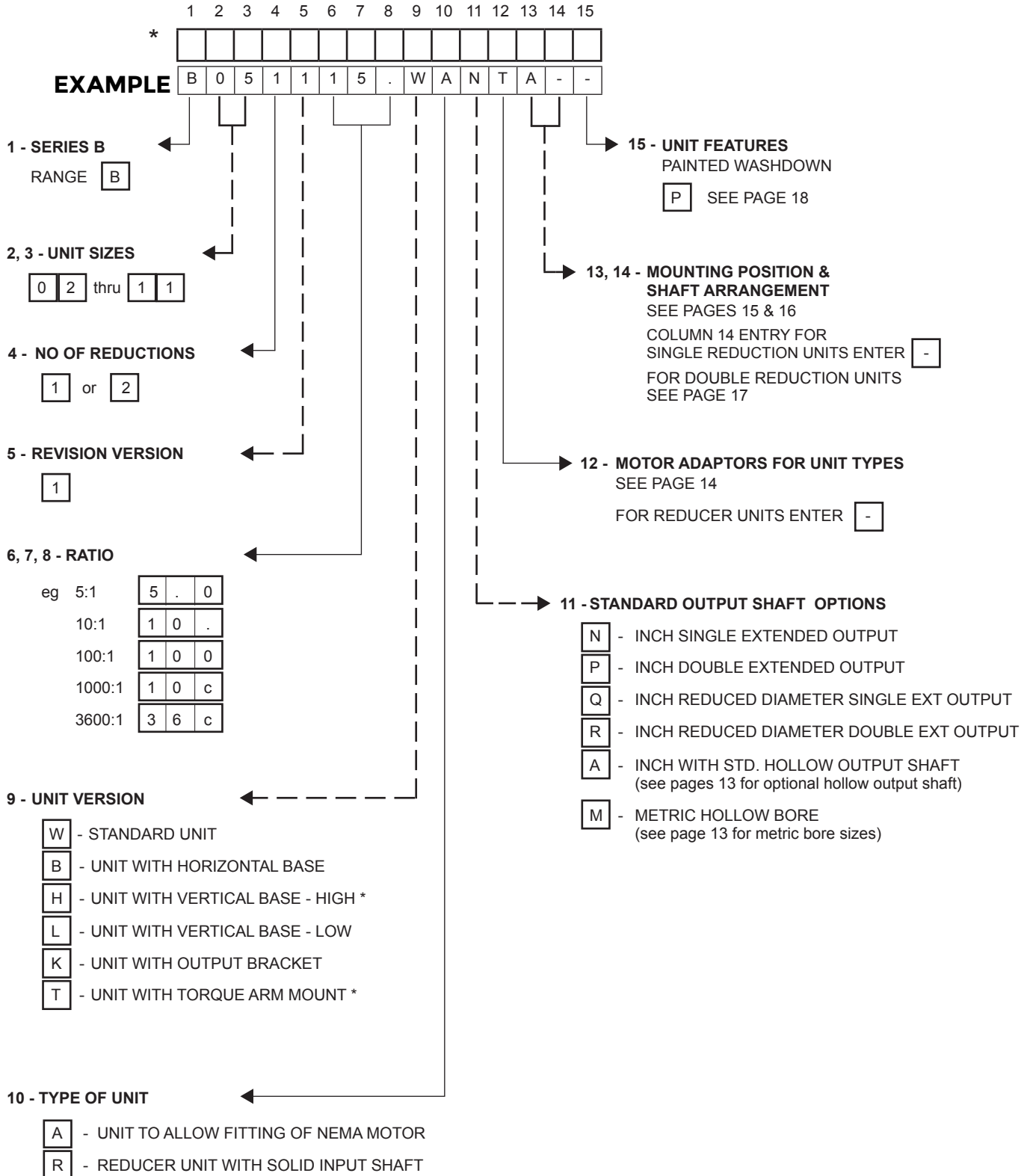

For IEC Motor applications contact Cone Drive

* Option not stocked; may require additional lead time

COLUMN 11 ENTRY

Inch Series Shafts

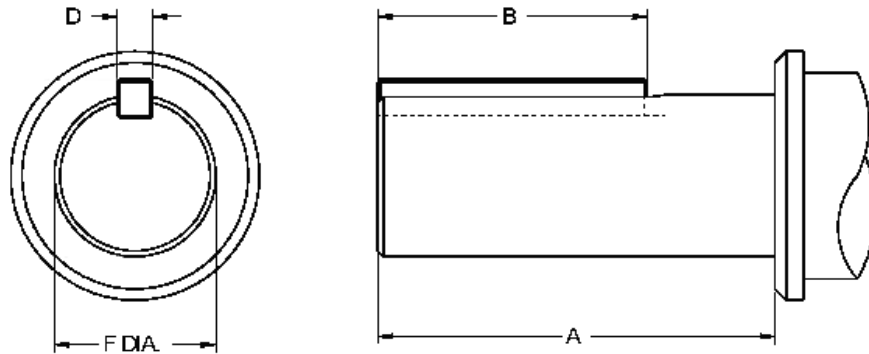

Unit Size	Type of Output Shaft	Column 11 Entry		A	B	D (Key)	F Dia.
		Single Extended	Double Extended				
B02	Standard Inch (in)	N	P	1.88	1.00	3/16 X 3/16	0.7495 ± 0.0005
	Reduced Dia. (in)	Q	R	1.88	1.00	3/16 X 3/16	0.6245 ± 0.0005
B03	Standard Inch (in)	N	P	1.99	1.13	3/16 X 3/16	0.7495 ± 0.0005
B04	Standard Inch (in)	N	P	1.97	1.25	1/4 X 1/4	0.9995 ± 0.0005
	Reduced Dia. (in)	Q	R	1.97	1.25	3/16 X 3/16	0.8745 ± 0.0005
B05	Standard Inch (in)	N	P	2.39	1.50	1/4 X 1/4	1.1245 ± 0.0005
	Reduced Dia. (in)	Q	R	2.39	1.50	1/4 X 1/4	0.9995 ± 0.0005
B06	Standard Inch (in)	N	P	2.77	1.88	1/4 X 1/4	1.1245 ± 0.0005
B08	Standard Inch (in)	N	P	2.68	1.94	3/8 X 3/8	1.4995 ± 0.0005
	Reduced Dia. (in)	Q	R	2.68	1.94	1/4 X 1/4	1.1245 ± 0.0005
B09	Standard Inch (in)	N	P	3.80	2.00	3/8 X 3/8	1.4995 ± 0.0005
	Reduced Dia. (in)	Q	R	3.80	2.00	1/4 X 1/4	1.2495 ± 0.0005
B10	Standard Inch (in)	N	P	3.83	2.25	3/8 X 3/8	1.4995 ± 0.0005
	Reduced Dia. (in)	Q	R	3.83	2.25	5/16 X 5/16	1.3745 ± 0.0005
B11	Standard Inch (in)	N	P	4.15	2.63	1/2 X 1/2	1.8745 ± 0.0005
	Reduced Dia. (in)	Q	R	4.15	2.63	3/8 X 3/8	1.6245 ± 0.0005

COLUMN 11 ENTRY

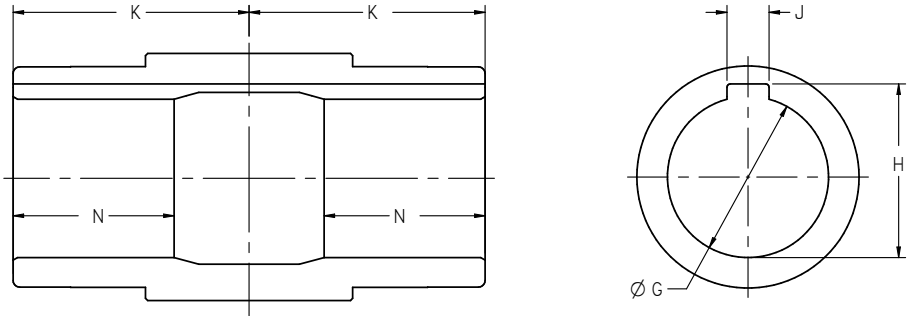

Output Bore

Standard Bore Sizes

Unit Size	Column 11 Entry	Ø G	J	H	K	N
Standard Inch (in)						
B02	A	1.0005 ± 0.0005	0.251	1.089	1.93	1.1
B03	A	1.0005 ± 0.0005	0.251	1.089	2.12	1.1
B04	A	1.4380 ± 0.0005	0.376	1.550	2.15	1.4
B05	A	1.4380 ± 0.0005	0.376	1.550	2.11	1.4
B06	A	1.4385 ± 0.0005	0.376	1.550	2.13	1.4
B08	A	1.9380 ± 0.0005	0.501	2.104	2.72	1.9
B09	A	2.1880 ± 0.0005	0.501	2.359	2.72	2.2
B10	A	2.1880 ± 0.0005	0.501	2.359	2.99	2.2
B11	A	2.9380 ± 0.0005	0.751	3.151	3.33	2.9
Standard Metric (mm)						
B02	M	20 + 0.021	6	22.84	49.0	29.0
B03	M	25 + 0.021	8	28.41	54.0	29.0
B04	M	35 + 0.025	10	38.41	54.5	36.5
B05	M	35 + 0.025	10	38.41	53.5	36.5
B06	M	35 + 0.025	10	38.41	54.0	36.5
B08	M	50 + 0.025	14	53.90	69.0	49.0
B09	M	55 + 0.030	16	59.40	69.0	55.6
B10	M	55 + 0.030	16	59.40	76.0	55.6
B11	M	75 + 0.030	20	80.00	84.5	74.6

Optional Bore Sizes

Ø G (in)	UNIT SIZE								
	B02	B03	B04	B05	B06	B08	B09	B10	B11
0.6255 ± 0.0005	E	E							
0.8755 ± 0.0005	—	F	E						
1.0005 ± 0.0005	A	A	F	E	E				
1.1255 ± 0.0005			G	F	F	E			
1.1880 ± 0.0005			—	G	G	—			
1.2505 ± 0.0005			J	J	J	—			
1.4385 ± 0.0005			A	A	A	J	E	E	E
1.7505 ± 0.0005						—	F	F	—
1.9380 ± 0.0005						A	G	G	—
2.1880 ± 0.0005							A	A	G
2.4380 ± 0.0005									J
2.9380 ± 0.0005									A



COLUMN 12 ENTRY

Nema C Face Motor Adaptor Kits

Single Stage Units

Motor Frame	UNIT SIZE								
	B0211	B0311	B0411	B0511	B0611	B0811	B0911	B1011	B1111
56C	U	T	T	T	T	Q	Q	Q	Q
143TC/145TC	W	V	V	V	V	R	R	R	R
182TC/184TC		X	X	X	X	T	T	T	T
213TC/215TC						V	V	V	V

Double Reduction Units













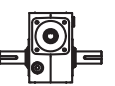





















UNIT SIZE					
B0521	B0621	B0821	B0921	B1021	B1121
U	U	T	T	T	T
W	W	V	V	V	V
		X	X	X	X

COLUMN 13 ENTRY

NOTE #1: "FIRST ANGLE" PROJECTION USED IN VIEWS BELOW 

NOTE #2: SINCE SERIES B IS A FULLY SEALED UNIT. THE CONFIGURATIONS SHOWN MAY BE MOUNTED IN ANY ORIENTATION.

NOTE #3: HAND OF ASSEMBLY VIEWS SHOWN LOOKING INTO HIGH SPEED (INPUT) SHAFT 

COLUMN 13 ENTRY		Std Unit With Hollow Output Shaft	Std Unit With Solid Output Shaft	Base Mount With Hollow Output Shaft	Base Mount With Solid Output Shaft	Output Bracket With Hollow Shaft	Output Bracket with Single Ext. Solid Shaft	Vertical Base With Hollow Shaft	Vertical Base With Single Ext. Solid Shaft
1									
A									
B									
C									
D									
2									
E									
F									

COLUMN 13 ENTRY

NOTES: "FIRST ANGLE" PROJECTION USED IN VIEWS BELOW



SINCE SERIES B IS A FULLY SEALED UNIT THE CONFIGURATIONS SHOWN MAY BE MOUNTED IN ANY ORIENTATION.

HAND OF ASSEMBLY VIEWS SHOWN LOOKING INTO HIGH SPEED (INPUT) SHAFT

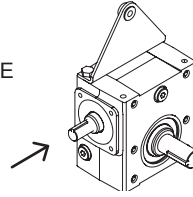

COLUMN 13 ENTRY		Torque Arm With Hollow Shaft	Torque Arm With Dbl. Ext. Solid Shaft	Torque Arm With Single Ext. Solid Shaft
J				
K				
L				
M				
N				
P				
Q				
R				

COLUMN 14 ENTRY

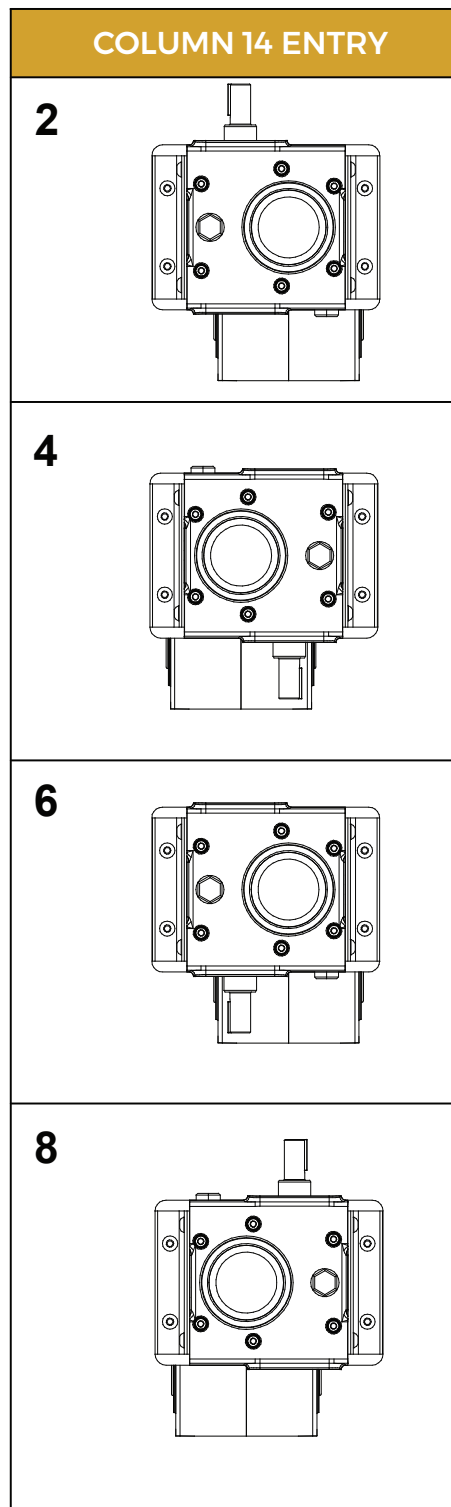
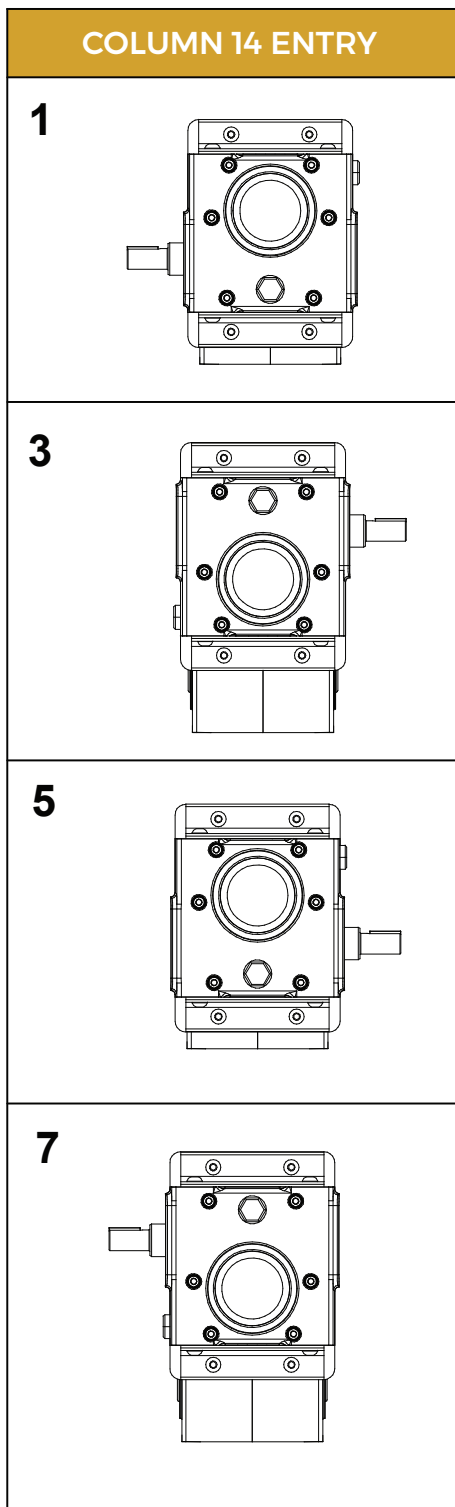

PRIMARY UNIT POSITION RELATIVE TO THE SECONDARY UNIT

MOUNTING POSITIONS 4 AND 6 NOT AVAILABLE FOR MOTOR READY UNITS

FOR SINGLE REDUCTION ENTER



GEAR UNIT FEATURES - COLUMN 15 ENTRY

COLUMN 15 ENTRY	Double Extended Input*	Painted Option	Light Washdown Duty Option	Washdown Duty Option	Special Features
-					
G	●				
H	●	●			
P		●			
S				●	
U			●		
Z					●

* Solid shaft extension to standard proportions on non drive end of input

SPECIAL UNIT FEATURES - WASHDOWN

Available for all single reduction motor ready reducers, with or without bases.

STANDARD FEATURES

- Vent - free eliminating contamination of reducer
- Smooth flat exterior is easily washable

PAINTED OPTION - Column 15 Entry H, P

- USDA approved white epoxy paint

LIGHT WASHDOWN DUTY OPTION - Column 15 Entry U

- Exposed portions of hollow output shaft plated for protection (bore not plated)
- Unused, tapped holes plugged
- Stainless steel fasteners
- Stainless steel solid output shafts
 - Excludes reduced-diameter shaft extension options
 - Excludes reduced-diameter output bushing options (bushing made from standard steel)
- Not painted

WASHDOWN DUTY OPTION - Column 15 Entry S,

- USDA approved white epoxy paint
- Exposed portions of hollow output shaft plated for protection (bore not plated)
- Unused, tapped holes plugged to simplify washdown
- Stainless steel fasteners
- Stainless steel solid output shafts
 - Excludes reduced-diameter shaft extension options
 - Excludes reduced-diameter output bushing options (bushing made from standard steel)

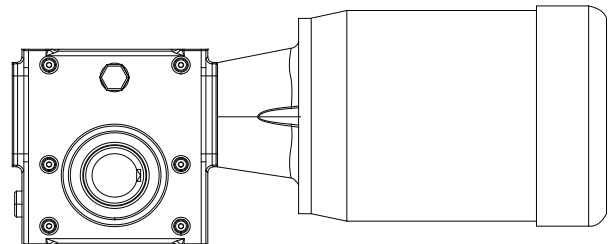

Gear unit selection is made by comparing actual loads with catalog ratings. Catalog ratings are based on a standard set of loading conditions, whereas actual load conditions vary according to type of application. Service Factors are therefore used to calculate an equivalent load to compare with catalog ratings. i.e. Equivalent Load = Actual Load x Service Factor

Two types of Service Factor must be considered: Mechanical Service Factor Fm and Thermal Service Factor Ft

MECHANICAL RATINGS & SERVICE FACTOR Fm

Mechanical ratings measure capacity in terms of life and/or strength, assuming 10 hr/day continuous running under uniform load conditions.

Catalog ratings allow for an 100% overload at starting, braking or momentarily during operation for a total of once per hour for each hour of operation.

The unit selected must therefore have a catalog rating at least equal to half maximum overload.

Mechanical Service Factor Fm (Table 1) is used to modify the actual load according to daily operating time, and type of loading.

Load characteristics for a wide range of applications are detailed on page 19, which are used in deciding the appropriate Service Factor Fm from Table 1.

If overloads can be calculated, or accurately assessed, actual loads should be used instead of Fm.

For units subject to frequent stop/start overloads in excess of 10 times per day, contact our Application Engineers.

For applications where high inertia loads are involved e.g. crane travel drives, slewing motion etc., unit selection should be referred to our Application Engineers.

THERMAL RATINGS & SERVICE FACTORS

The Thermal ratings are a measure of the gear units ability to dissipate heat. If they are exceeded the lubricant may overheat and breakdown, resulting in gear failure.

Catalog thermal limitations are based on the unit operating continuously in an environment with an ambient temperature equal to 68°F. The thermal rating is affected by ambient temperature. To account for these varying conditions, the service factors given in table 2 should be applied to the catalog thermal ratings as follows:

- P_{therm} = (P_t x F_t x efficiency) / 100
- P_t = Catalog input power thermal rating (HP)
- P_{therm} = Allowable output power thermal rating (HP)
- F_t = Service factor for ambient temperature (see Table 2)

TABLE 1 / Mechanical service factor Fm

Prime Mover	Duration of Service hrs per day	Load Classification-Driven Machine		
		Uniform	Moderate Shock	Heavy Shock
Electric motor, steam turbine or hydraulic motor	Under 3	0.80	1.00	1.50
	3 to 10	1.00	1.25	1.75
	Over 10	1.25	1.50	2.00
Multi-cylinder internal combustion engine	Under 3	1.00	1.25	1.75
	3 to 10	1.25	1.50	2.00
	Over 10	1.50	1.75	2.25
Single cylinder internal combustion engine	Under 3	1.25	1.50	2.00
	3 to 10	1.50	1.75	2.25
	Over 10	1.75	2.00	2.50

TABLE 2 / Thermal service factor Ft

Ambient Temperature °F	-20	0	20	40	60	68	80	100	120
Factor Ft	1.64	1.50	1.36	1.22	1.07	1.00	0.92	0.77	0.63

GENERAL

When selecting units, use actual load required to be transmitted, not rating of prime mover. Wherever possible use required output torque (lb-in). Catalog also gives input power rating (HP), being the power required from prime mover allowing for gear unit efficiency. When units transmit less than rated output torque, required input power may be reduced pro-rata to decide capacity of prime mover.

EXAMPLE APPLICATION DETAILS

Absorbed power of driven machine = 0.375 HP
 Output speed of gearbox or Input speed of machine = 30 RPM
 Application = Uniformly loaded belt conveyor

Duration of service (hours per day) = 24 hrs
 Motor speed = 3 phase electric motor, 4 pole, 1750 RPM
 Ambient temperature = 68°F

1 DETERMINE RATIO OF GEARBOX REQUIRED

$$\frac{\text{Motor speed}}{\text{Gearbox output speed}} = \frac{1750}{30} = 58.33$$

Refer to rating tables (pages 46 - 49) for nearest standard ratio = 60:1

3 DETERMINE REQUIRED MECHANICAL OUTPUT TORQUE CAPACITY OF GEARBOX

$$\text{Absorbed output torque} = \frac{\text{Absorbed power} \times 63025}{\text{Gearbox output speed}}$$

$$\frac{0.375 \times 63025}{30} = 788 \text{ lb.in}$$

$$\text{Required mechanical output torque} = \text{Absorbed output} \times \text{Fm torque}$$

$$788 \times 1.25 = 985 \text{ lb.in}$$

***NOTE:** Reducer efficiency not used.
 Generated torque will vary based on efficiency

2 DETERMINE MECHANICAL SERVICE FACTOR (Fm)

Refer to Load Classification by Application table on page 20.

Application = Uniformly fed, belt conveyor

Conveyors-uniformly loaded or fed	
apron	U
assembly	U
belt	U
bucket	U
chain	U

U = Uniform loading

Refer to mechanical service factor (Fm), table 1, page 21
 Duration of service (hours per day) = 24 hrs

Prime Mover	Duration of Service-hrs per day	Load Classification-drive	
		Uniform	Moderate Shock
Electric motor, steam turbine or hydraulic motor	Under 3	0.80	1.00
	3 to 10	1.00	1.25
	Over 10	1.25	1.50

Therefore mechanical service factor (Fm) = 1.25

4 DETERMINE SIZE OF GEAR BOX REQUIRED

Refer to ratings tables, Input speed = 1750RPM.

RATIO	OUTPUT SPEED	CAPACITY	SIZE OF UNIT								
			B02	B03	B04	B05	B06	B08	B09	B10	B11
60	29	Input Power HP (mech)	0.29	0.38	0.50	0.64	0.98	1.24	1.70	2.05	2.52
		Input Power HP (therm)	0.29	0.38	0.50	0.64	0.98	1.24	1.70	2.05	2.52
		Output Torque lb-in (mech)	272	404	570	782	1300	1700	2430	2990	3740
		Efficiency	43	49	53	57	61	64	66	67	69

Mechanical output torque capacity must be equal or more than required mechanical output torque capacity of gear box. Required mechanical output torque capacity = 985 lb.in. At a 60:1 ratio, nominal output speed 29 an B06 unit has a mechanical output torque capacity of 1300 lb-in. Therefore the unit is acceptable.

5 DETERMINE REQUIRED OUTPUT TORQUE & POWER

(Based on known reducer running efficiency)

Refer to ratings tables to determine gear unit efficiency

RATIO	OUTPUT SPEED	CAPACITY	SIZE OF UNIT								
			B02	B03	B04	B05	B06	B08	B09	B10	B11
60	29	Input Power HP (mech)	0.29	0.38	0.50	0.64	0.98	1.24	1.70	2.05	2.52
		Input Power HP (therm)	0.29	0.38	0.50	0.64	0.98	1.24	1.70	2.05	2.52
		Output Torque lb-in (mech)	272	404	570	782	1300	1700	2430	2990	3740
		Efficiency	43	49	53	57	61	64	66	67	69

Running efficiency of B06 60:1 at 1750 RPM = 61%

$$\text{Output Torque} = \frac{63025 \times \text{Input Power} \times \text{Ratio} \times \text{Efficiency}}{\text{Input RPM}}$$

$$\text{Output Torque} = \frac{63025 \times 0.375 \times 60 \times 0.61}{1750}$$

Output Torque = 494 Lb. in (This is the actual output torque produced with 0.375 Hp input power.)



If the application requires greater output torque then the input power must be increased, in which case the input power rating of the gearbox must be checked.

$$\text{Required motor power} = \frac{\text{Input power}}{\text{Efficiency}} \times 100 = \frac{0.375}{61} \times 100 = 0.615 \text{ HP}$$

Next largest motor is 0.75 Hp (The B0611 60:1 is rated for 0.98 Hp and is acceptable)

6 DETERMINE THERMAL SERVICE FACTOR (Ft)

Refer to page 19

Ambient temperature = 68°F

Ambient temperature °F	-20	0	20	40	60	68
Factor Ft	1.64	1.50	1.36	1.22	1.07	1.0

$$F_t = 1.0$$

7 CHECK THERMAL CAPACITY OF GEARBOX SELECTED

DETERMINE THERMAL INPUT POWER CAPACITY (Pt)

Refer to ratings tables

RATIO	OUTPUT SPEED	CAPACITY	SIZE OF UNIT								
			B0211	B0311	B0411	B0511	B0611	B0811	B0911	B1011	B1111
60	29	Input Power HP (mech)	0.29	0.38	0.50	0.64	0.98	1.24	1.70	2.05	2.52
		Input Power HP (therm)	0.42	0.55	0.81	0.92	1.31	1.79	2.13	2.70	2.88
		Output Torque lb-in (mech)	272	404	570	782	1305	1699	2427	2986	3739
		Efficiency	0.43	0.49	0.53	0.57	0.61	0.64	0.66	0.67	0.69

$$P_t = 1.31 \text{ HP}$$

8 DETERMINE ALLOWABLE OUTPUT POWER THERMAL RATING (P_{therm})

$$\begin{aligned}
 P_{\text{therm}} &= \frac{P_t \times F_t \times \text{efficiency}}{100} \\
 &= \frac{0.98 \times 1.0 \times 61}{100} \\
 &= 0.60 \text{ HP}
 \end{aligned}$$

Thermal output power capacity (P_{therm}) must be equal or more than absorbed output power to drive machine

$$\text{Absorbed output power} = 0.375 \text{ HP} \quad P_{\text{therm}} = 0.60 \text{ HP}$$

Therefore unit is acceptable.

NOTE: If any of the following conditions occur then consult our Application Engineers:

- Inertia of the Driven Machine (Referred to motor speed) >10 Inertia of Gear Unit plus Motor
- Ambient temperature is above 120°F

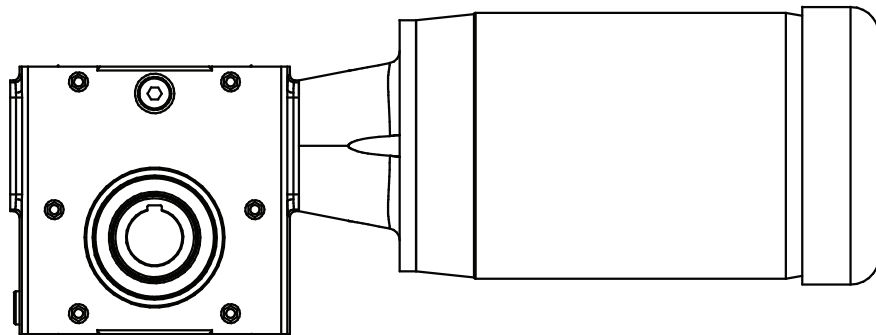

SERIES B

DIMENSIONAL DATA



STANDARD UNIT

REDUCER

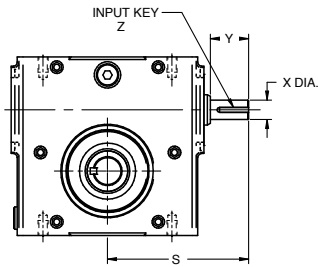

MOTORIZED

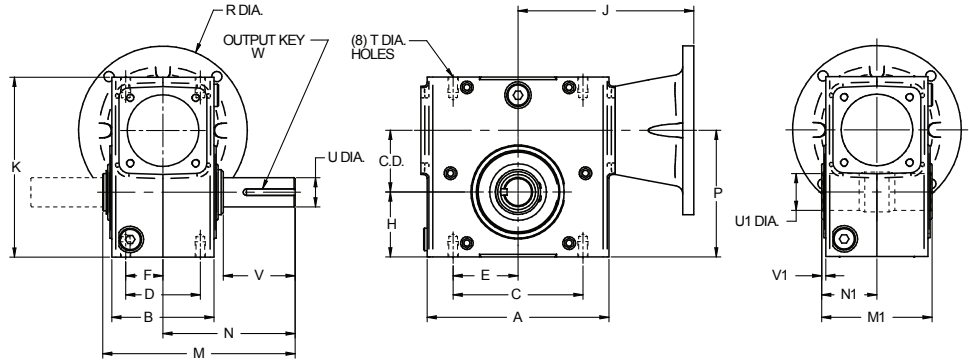

Case Size	C.D.	A	B	C	D	E	F	H	K	M	M1	N	N1	P	T Dia.
B02	1.33	4.33	2.76	3.25	2.00	1.63	1.00	1.72	4.66	6.10	3.85	4.00	1.93	3.05	M8 x 0.47
B03	1.54	5.23	3.94	4.19	2.75	2.10	1.38	1.91	5.35	6.61	4.25	4.31	2.12	3.45	M8 x 0.47
B04	1.75	5.98	3.94	4.19	2.75	2.10	1.38	2.06	5.75	6.65	4.29	4.31	2.15	3.81	M8 x 0.47
B05	1.97	6.00	3.94	5.00	2.88	2.50	1.44	2.28	6.38	7.00	4.21	4.69	2.11	4.25	M10 x 0.59
B06	2.38	7.00	3.94	5.00	2.88	2.50	1.44	2.50	6.93	7.41	4.25	5.09	2.13	4.88	M10 x 0.59
B08	2.62	7.50	5.12	6.38	3.38	3.19	1.69	2.94	7.99	8.58	5.43	5.63	2.72	5.57	M10 x 0.59
B09	3.00	9.00	5.12	7.00	4.00	3.50	2.00	3.25	8.88	9.70	5.43	6.75	2.72	6.25	M12 x 0.71
B10	3.25	9.05	5.67	7.50	4.00	3.75	2.00	3.50	9.38	10.28	5.98	7.06	2.99	6.75	M12 x 0.71
B11	3.54	9.50	5.12	7.50	4.00	3.75	2.00	3.39	9.84	11.34	6.65	7.75	3.33	6.93	M16 x 0.87

Case Size	REDUCER						MOTORIZED						OUTPUT SHAFT				W-KEY		WT (LBS)
	C.D.	X Dia.	Y	SQ.	LC	S	56C/ 143/145TC	J	R Dia.	J	R Dia.	J	R Dia.	U Dia.	U1 Dia.	V	VI	SQ.	
B02	1.33	0.625	1.31	3/16	1.00	4.22	4.74	6.50	NA	NA	NA	NA	0.750	1.000	1.88	0.12	3/16	1.00	9
B03	1.54	0.750	1.48	3/16	1.13	4.87	5.92	6.50	6.16	9.00	NA	NA	0.750	1.000	1.99	0.08	3/16	1.13	14
B04	1.75	0.750	1.48	3/16	1.13	5.13	6.18	6.50	6.42	9.00	NA	NA	1.000	1.438	1.97	0.08	1/4	1.25	16
B05	1.97	0.750	1.48	3/16	1.13	5.20	6.34	6.50	6.58	9.00	NA	NA	1.125	1.438	2.39	0.08	1/4	1.50	18
B06	2.38	0.750	1.48	3/16	1.13	5.47	6.77	6.50	7.01	9.00	NA	NA	1.125	1.438	2.77	0.08	1/4	1.88	23
B08	2.62	1.188	2.69	1/4	2.25	7.23	7.24	6.50	7.59	9.00	7.59	9.00	1.500	1.938	2.68	0.08	3/8	1.97	40
B09	3.00	1.188	2.69	1/4	2.25	7.63	7.64	6.50	7.98	9.00	7.98	9.00	1.500	2.188	3.80	0.08	3/8	2.00	47
B10	3.25	1.188	2.69	1/4	2.25	7.64	7.72	6.50	8.06	9.00	8.06	9.00	1.500	2.188	3.83	0.08	3/8	2.25	50
B11	3.54	1.188	2.95	1/4	2.62	8.39	8.15	6.50	8.50	9.00	8.50	9.00	1.875	2.938	4.15	0.10	1/2	2.63	70

UNIT WITH HORIZONTAL BASE (Over Driven)

REDUCER

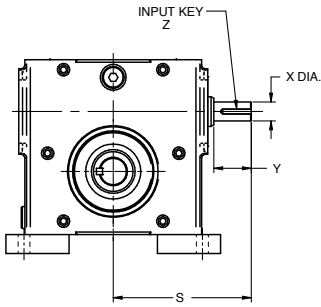

MOTORIZED

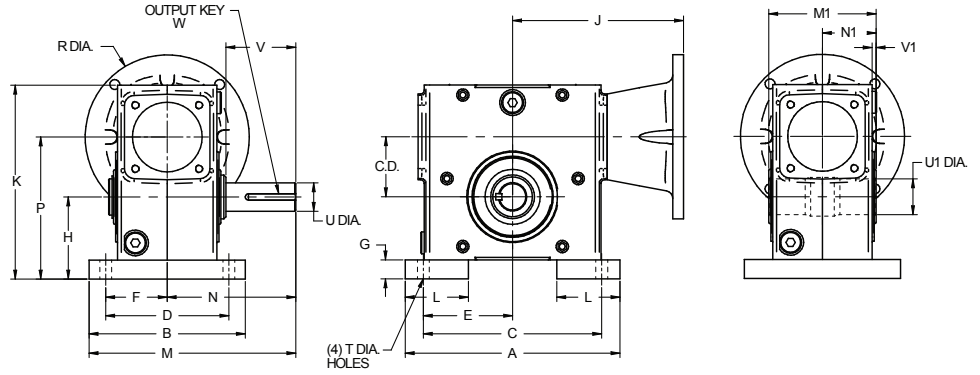

Case Size	C.D.	A	B	C	D	E	F	G	H	K	L	M	M1	N	N1	P	T Dia.
B02	1.33	5.38	4.19	4.380	3.310	2.190	1.655	0.53	2.25	5.19	1.50	6.09	3.85	4.00	1.93	3.58	11/32
B03	1.54	6.44	5.44	5.250	4.312	2.625	2.156	0.59	2.50	5.94	1.50	7.03	4.25	4.31	2.12	4.04	13/32
B04	1.75	7.00	5.69	5.750	4.500	2.875	2.250	0.69	2.75	6.44	2.00	7.16	4.29	4.31	2.15	4.50	13/32
B05	1.97	7.75	5.94	6.380	4.690	3.190	2.345	0.72	3.00	7.10	2.00	7.66	4.21	4.69	2.11	4.97	15/32
B06	2.38	8.50	6.19	7.063	4.875	3.532	2.438	0.75	3.25	7.68	2.50	8.19	4.25	5.09	2.13	5.63	15/32
B08	2.62	9.63	6.66	8.000	5.250	4.000	2.625	0.75	3.69	8.74	2.50	8.96	5.43	5.63	2.72	6.31	17/32
B09	3.00	10.00	7.50	8.440	5.880	4.220	2.940	0.75	4.00	9.63	2.00	10.50	5.43	6.75	2.72	7.00	17/32
B10	3.25	11.19	7.66	9.500	6.125	4.750	3.063	0.88	4.38	10.25	2.50	10.89	5.98	7.06	2.99	7.63	17/32
B11	3.54	11.08	7.71	9.500	6.120	4.750	3.060	1.61	5.00	11.45	2.50	11.61	6.65	7.75	3.33	8.54	9/16

Case Size	REDUCER						MOTORIZED						OUTPUT SHAFT				W-KEY		WT (LBS)	
	C.D.	INPUT SHAFT	Z-KEY				56C/143/145TC	182/184TC	213/215TC					U Dia.	U1 Dia.	V	VI	SQ.		LG
	X Dia.	Y	SQ.	LG	S	J	R Dia.	J	R Dia.	J	R Dia.	J	R Dia.							
B02	1.33	0.625	1.31	3/16	1.00	4.22	4.74	6.50	NA	NA	NA	NA	0.750	1.000	1.88	0.12	3/16	1.00	10	
B03	1.54	0.750	1.48	3/16	1.13	4.87	5.92	6.50	6.16	9.00	NA	NA	0.750	1.000	1.99	0.08	3/16	1.13	15	
B04	1.75	0.750	1.48	3/16	1.13	5.13	6.18	6.50	6.42	9.00	NA	NA	1.000	1.438	1.97	0.08	1/4	1.25	18	
B05	1.97	0.750	1.48	3/16	1.13	5.20	6.34	6.50	6.58	9.00	NA	NA	1.125	1.438	2.39	0.08	1/4	1.50	20	
B06	2.38	0.750	1.48	3/16	1.13	5.47	6.77	6.50	7.01	9.00	NA	NA	1.125	1.438	2.77	0.08	1/4	1.88	25	
B08	2.62	1.188	2.69	1/4	2.25	7.23	7.24	6.50	7.59	9.00	7.59	9.00	1.500	1.938	2.68	0.08	3/8	1.97	43	
B09	3.00	1.188	2.69	1/4	2.25	7.63	7.64	6.50	7.98	9.00	7.98	9.00	1.500	2.188	3.80	0.08	3/8	2.00	50	
B10	3.25	1.188	2.69	1/4	2.25	7.64	7.72	6.50	8.06	9.00	8.06	9.00	1.500	2.188	3.83	0.08	3/8	2.25	54	
B11	3.54	1.188	2.95	1/4	2.62	8.39	8.15	6.50	8.50	9.00	8.50	9.00	1.875	2.938	4.15	0.10	1/2	2.63	75	



UNIT WITH HORIZONTAL BASE (Under Driven)

REDUCER

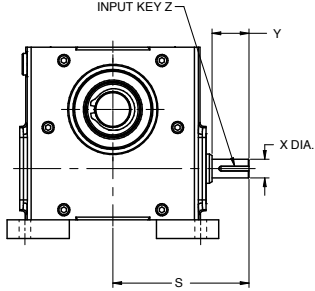

MOTORIZED

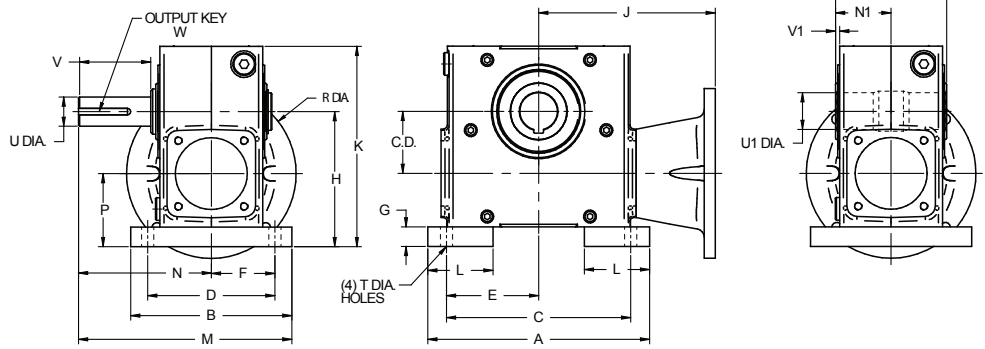

Case Size	C.D.	A	B	C	D	E	F	G	H	K	L	M	M1	N	N1	P	T Dia.
B02	1.33	5.38	4.19	4.380	3.310	2.190	1.655	0.53	3.47	5.19	1.50	6.09	3.85	4.00	1.93	2.14	11/32
B03	1.54	6.44	5.44	5.250	4.312	2.625	2.156	0.59	4.03	5.94	1.50	7.03	4.25	4.31	2.12	2.49	13/32
B04	1.75	7.00	5.69	5.750	4.500	2.875	2.250	0.69	4.38	6.44	2.00	7.16	4.29	4.31	2.15	2.63	13/32
B05	1.97	7.75	5.94	6.380	4.690	3.190	2.345	0.72	4.82	7.10	2.00	7.66	4.21	4.69	2.11	2.85	15/32
B06	2.38	8.50	6.19	7.063	4.875	3.532	2.438	0.75	5.18	7.68	2.50	8.19	4.25	5.09	2.13	2.80	15/32
B08	2.62	9.63	6.66	8.000	5.250	4.000	2.625	0.75	5.80	8.74	2.50	8.96	5.43	5.63	2.72	3.18	17/32
B09	3.00	10.00	7.50	8.440	5.880	4.220	2.940	0.75	6.38	9.63	2.00	10.50	5.43	6.75	2.72	3.38	17/32
B10	3.25	11.19	7.66	9.500	6.125	4.750	3.063	0.88	6.75	10.25	2.50	10.89	5.98	7.06	2.99	3.50	17/32
B11	3.54	11.08	7.71	9.500	6.120	4.750	3.060	1.61	8.07	11.45	2.50	11.61	6.65	7.75	3.33	4.53	9/16

Case Size	C.D.	REDUCER					MOTORIZED						OUTPUT SHAFT				W-KEY		WT (lbs)
		X Dia.	Y	SQ.	LG	S	56C/ 143/145TC	J	R Dia.	J	R Dia.	J	R Dia.	U Dia.	U1 Dia.	V	VI	SQ.	
B02	1.33	0.625	1.31	3/16	1.00	4.22	4.74	6.50	NA	NA	NA	NA	0.750	1.000	1.88	0.12	3/16	1.00	10
B03	1.54	0.750	1.48	3/16	1.13	4.87	5.92	6.50	6.16	9.00	NA	NA	0.750	1.000	1.99	0.08	3/16	1.13	15
B04	1.75	0.750	1.48	3/16	1.13	5.13	6.18	6.50	6.42	9.00	NA	NA	1.000	1.438	1.97	0.08	1/4	1.25	18
B05	1.97	0.750	1.48	3/16	1.13	5.20	6.34	6.50	6.58	9.00	NA	NA	1.125	1.438	2.39	0.08	1/4	1.50	20
B06	2.38	0.750	1.48	3/16	1.13	5.47	6.77	6.50	7.01	9.00	NA	NA	1.125	1.438	2.77	0.08	1/4	1.88	25
B08	2.62	1.188	2.69	1/4	2.25	7.23	7.24	6.50	7.59	9.00	7.59	9.00	1.500	1.938	2.68	0.08	3/8	1.97	43
B09	3.00	1.188	2.69	1/4	2.25	7.63	7.64	6.50	7.98	9.00	7.98	9.00	1.500	2.188	3.80	0.08	3/8	2.00	50
B10	3.25	1.188	2.69	1/4	2.25	7.64	7.72	6.50	8.06	9.00	8.06	9.00	1.500	2.188	3.83	0.08	3/8	2.25	54
B11	3.54	1.188	2.95	1/4	2.62	8.39	8.15	6.50	8.50	9.00	8.50	9.00	1.875	2.938	4.15	0.10	1/2	2.63	75

UNIT WITH VERTICAL BASE (High & Low)

REDUCER

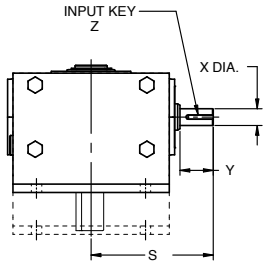

MOTORIZED

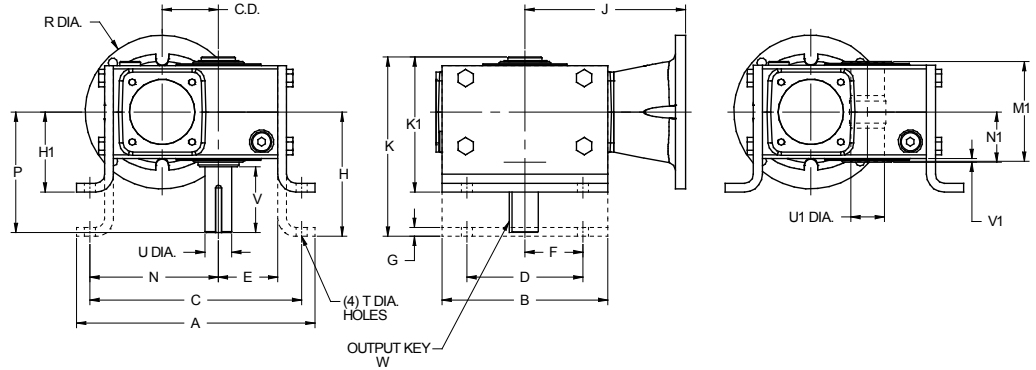

Case Size	C.D.	A	B	C	D	E	F	G	H	H1	K	K1	M1	N	N1	P	T Dia.
B02	1.33	7.09	4.33	6.15	3.25	1.72	1.63	0.25	3.56	2.31	5.66	4.41	3.85	3.69	1.93	4.00	11/32
B03	1.54	8.04	5.23	6.98	4.00	1.91	2.00	0.25	4.38	3.00	6.68	5.30	4.25	4.26	2.12	4.31	13/32
B04	1.75	8.44	5.98	7.38	4.00	2.06	2.00	0.31	4.38	3.00	6.72	5.34	4.29	4.51	2.15	4.31	13/32
B05	1.97	9.50	6.00	8.38	4.88	2.28	2.44	0.38	4.88	3.13	7.19	5.44	4.21	5.10	2.11	4.69	15/32
B06	2.38	10.06	7.00	8.95	4.88	2.50	2.44	0.38	5.25	3.38	7.57	5.70	4.25	5.44	2.13	5.09	15/32
B08	2.62	11.69	7.50	10.13	5.75	2.94	2.88	0.38	5.59	3.63	8.54	6.58	5.43	6.14	2.72	5.63	17/32
B09	3.00	13.25	9.00	11.14	6.00	3.25	3.00	0.38	5.88	3.94	8.83	6.89	5.43	6.76	2.72	6.75	17/32
B10	3.25	13.37	9.05	11.87	6.13	3.50	3.07	0.50	6.25	4.69	9.47	7.91	5.98	7.12	2.99	7.06	17/32
B11	3.54	16.84	9.50	14.88	7.88	3.39	3.94	0.50	7.50	5.00	11.09	8.59	6.65	8.99	3.33	7.75	9/16

Case Size	REDUCER						MOTORIZED						OUTPUT SHAFT				W-KEY		WT (lbs)
	C.D.	INPUT SHAFT	Z-KEY				56C/143/145TC	182/184TC	213/215TC										
	X Dia.	Y	SQ.	LG	S	J	R Dia.	J	R Dia.	J	R Dia.	U Dia.	U1 Dia.	V	V1	SQ.	LG		
B02	1.33	0.625	1.31	3/16	1.00	4.22	4.74	6.50	NA	NA	NA	NA	0.750	1.000	1.88	0.12	3/16	1.00	10
B03	1.54	0.750	1.48	3/16	1.13	4.87	5.92	6.50	6.16	9.00	NA	NA	0.750	1.000	1.99	0.08	3/16	1.13	15
B04	1.75	0.750	1.48	3/16	1.13	5.13	6.18	6.50	6.42	9.00	NA	NA	1.000	1.438	1.97	0.08	1/4	1.25	18
B05	1.97	0.750	1.48	3/16	1.13	5.20	6.34	6.50	6.58	9.00	NA	NA	1.125	1.438	2.39	0.08	1/4	1.50	20
B06	2.38	0.750	1.48	3/16	1.13	5.47	6.77	6.50	7.01	9.00	NA	NA	1.125	1.438	2.77	0.08	1/4	1.88	25
B08	2.62	1.188	2.69	1/4	2.25	7.23	7.24	6.50	7.59	9.00	7.59	9.00	1.500	1.938	2.68	0.08	3/8	1.97	44
B09	3.00	1.188	2.69	1/4	2.25	7.63	7.64	6.50	7.98	9.00	7.98	9.00	1.500	2.188	3.80	0.08	3/8	2.00	51
B10	3.25	1.188	2.69	1/4	2.25	7.64	7.72	6.50	8.06	9.00	8.06	9.00	1.500	2.188	3.83	0.08	3/8	2.25	55
B11	3.54	1.188	2.95	1/4	2.62	8.39	8.15	6.50	8.50	9.00	8.50	9.00	1.875	2.938	4.15	0.10	1/2	2.63	76



UNIT WITH OUTPUT BRACKET

REDUCER

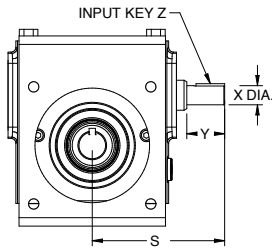

MOTORIZED

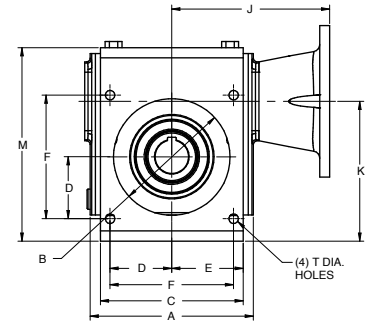
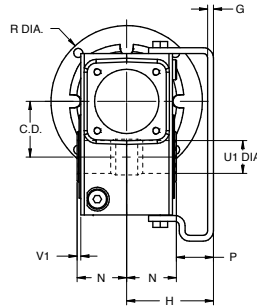
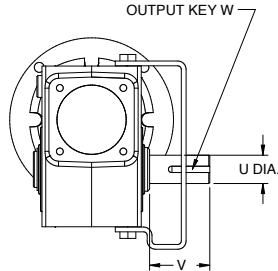

Case Size	C.D.	A	B	C	D	E	F	G	H	K	M	N	P	T Dia.
B02	1.33	4.33	3.62	4.25	1.77	2.13	3.54	0.19	3.00	3.75	5.55	1.93	1.07	11/32
B03	1.54	5.23	3.62	4.75	1.77	2.38	3.54	0.19	3.56	4.07	6.16	2.12	1.44	11/32
B04	1.75	5.98	4.06	4.81	2.08	2.41	4.16	0.19	3.50	4.53	6.66	2.15	1.35	11/32
B05	1.97	6.00	4.50	5.75	2.30	2.88	4.60	0.19	3.75	5.15	7.47	2.11	1.64	13/32
B06	2.38	7.00	5.00	6.13	2.65	3.07	5.30	0.25	3.72	6.00	8.30	2.13	1.59	13/32
B08	2.62	7.50	6.00	7.18	2.83	3.59	5.66	0.25	4.06	6.57	9.25	2.72	1.34	13/32
B09	3.00	9.00	7.00	8.50	3.18	4.25	6.36	0.25	4.50	7.14	10.02	2.72	1.78	13/32
B10	3.25	9.05	7.00	8.50	3.54	4.25	7.07	0.25	5.25	8.04	10.91	2.99	2.26	9/16
B11	3.54	9.50	8.56	9.50	3.54	4.75	7.07	0.25	5.25	9.19	12.35	3.33	1.92	9/16

Case Size	C.D.	REDUCER					MOTORIZED						OUTPUT SHAFT				W-KEY		WT (lbs)
		X Dia.	Y	SQ.	LG	S	56C/ 143/145TC	J	R Dia.	J	R Dia.	J	R Dia.	U Dia.	U1 Dia.	V	VI	SQ.	
B02	1.33	0.625	1.31	3/16	1.00	4.22	4.74	6.50	NA	NA	NA	NA	0.750	1.000	1.88	0.12	3/16	1.00	9
B03	1.54	0.750	1.48	3/16	1.13	4.87	5.92	6.50	6.16	9.00	NA	NA	0.750	1.000	1.99	0.08	3/16	1.13	14
B04	1.75	0.750	1.48	3/16	1.13	5.13	6.18	6.50	6.42	9.00	NA	NA	1.000	1.438	1.97	0.08	1/4	1.25	16
B05	1.97	0.750	1.48	3/16	1.13	5.20	6.34	6.50	6.58	9.00	NA	NA	1.125	1.438	2.39	0.08	1/4	1.50	18
B06	2.38	0.750	1.48	3/16	1.13	5.47	6.77	6.50	7.01	9.00	NA	NA	1.125	1.438	2.77	0.08	1/4	1.88	23
B08	2.62	1.188	2.69	1/4	2.25	7.23	7.24	6.50	7.59	9.00	7.59	9.00	1.500	1.938	2.68	0.08	3/8	1.97	40
B09	3.00	1.188	2.69	1/4	2.25	7.63	7.64	6.50	7.98	9.00	7.98	9.00	1.500	2.188	3.80	0.08	3/8	2.00	47
B10	3.25	1.188	2.69	1/4	2.25	7.64	7.72	6.50	8.06	9.00	8.06	9.00	1.500	2.188	3.83	0.08	3/8	2.25	50
B11	3.54	1.188	2.95	1/4	2.62	8.39	8.15	6.50	8.50	9.00	8.50	9.00	1.875	2.938	4.15	0.10	1/2	2.63	70

STANDARD DOUBLE REDUCTION UNIT (No Base)

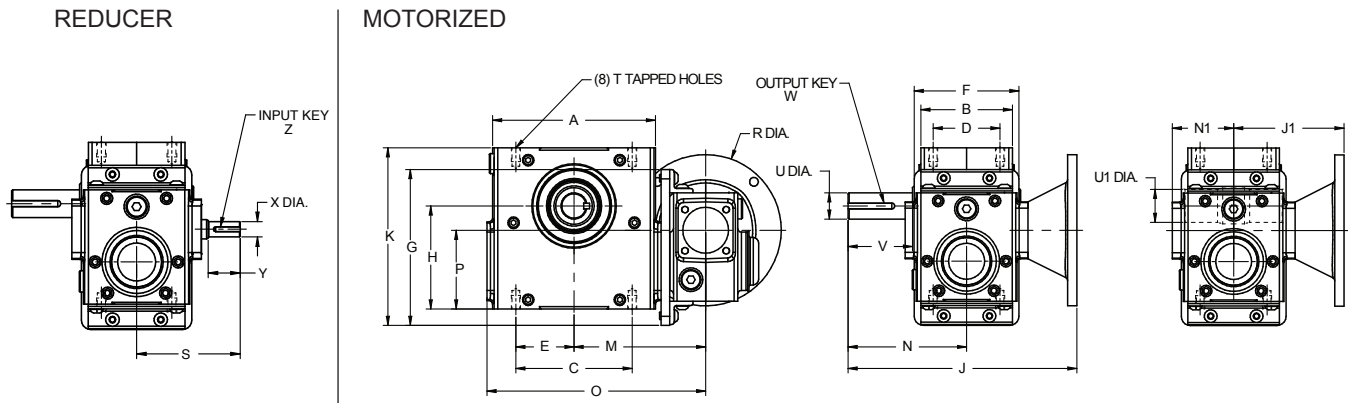

Size	A	B	C	D	E	F	G	H	K	M	N	N1	O	P	T Dia.
B0521	6.00	3.94	5.00	2.88	2.50	4.50	6.69	4.10	7.00	5.28	4.69	2.64	8.58	3.46	M10 x 0.59
B0621	7.00	3.94	5.00	2.88	2.50	4.50	6.69	4.43	7.63	5.71	5.09	2.64	9.45	3.39	M10 x 0.59
B0821	7.50	5.12	6.38	3.38	3.19	5.98	8.27	5.05	8.87	6.79	5.63	3.15	11.00	4.18	M10 x 0.59
B0921	9.00	5.12	7.00	4.00	3.50	5.98	8.27	5.63	9.56	7.19	6.75	3.15	11.79	4.38	M12 x 0.71
B1021	9.05	5.67	7.50	4.00	3.75	5.98	8.82	5.88	10.25	7.22	7.06	3.31	11.91	4.59	M12 x 0.71
B1121	9.50	5.12	7.50	4.00	3.75	5.98	8.82	6.46	10.43	7.66	7.75	3.31	12.78	4.88	M16 x 0.87

Case Size	REDUCER					MOTORIZED						OUTPUT SHAFT		W-KEY		WT (LBS)	
	INPUT SHAFT		Z-KEY		S	56C/143/145TC			182/184TC			U Dia.	U1 Dia.	V	SQ.		LG
X Dia.	Y	SQ.	LG	J		J1	R Dia.	J	J1	R Dia.	U Dia.					U1 Dia.	
B0521	0.625	1.31	3/16	1.00	4.22	9.43	4.74	6.50	NA	NA	NA	1.125	1.438	2.39	1/4	1.50	32
B0621	0.625	1.31	3/16	1.00	4.22	9.83	4.74	6.50	NA	NA	NA	1.125	1.438	2.77	1/4	1.88	37
B0821	0.750	1.48	3/16	1.13	5.13	11.81	6.18	6.50	NA	NA	NA	1.500	1.938	2.68	3/8	1.94	65
B0921	0.750	1.48	3/16	1.13	5.13	12.93	6.18	6.50	NA	NA	NA	1.500	2.188	3.80	3/8	2.00	72
B1021	0.750	1.48	3/16	1.13	5.20	13.40	6.34	6.50	13.68	6.62	9.00	1.500	2.188	3.83	3/8	2.25	78
B1121	0.750	1.48	3/16	1.13	5.20	14.09	6.34	6.50	14.37	6.62	9.00	1.875	2.938	4.15	1/2	2.63	98



STANDARD DOUBLE REDUCTION UNIT (No Base)

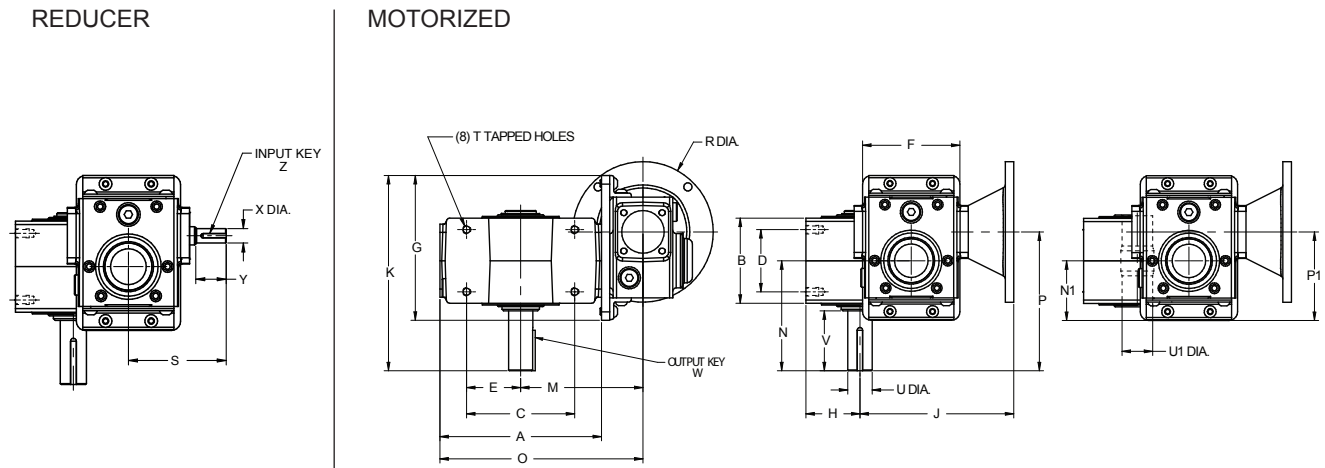

Size	A	B	C	D	E	F	G	H	K	M	N	N1	O	P	P1	T Dia.
B0521	6.61	3.94	5.00	2.88	2.50	4.50	6.69	2.28	8.63	5.28	4.69	2.76	8.58	6.02	4.09	M10x 0.59
B0621	7.48	3.94	5.00	2.88	2.50	4.50	6.69	2.50	9.03	5.71	5.09	2.76	9.45	6.42	4.09	M10x 0.59
B0821	8.43	5.12	6.38	3.38	3.19	5.98	8.27	2.94	10.59	6.79	5.63	3.31	11.00	7.38	5.06	M10x 0.59
B0921	9.21	5.12	7.00	4.00	3.50	5.98	8.27	3.25	11.71	7.19	6.75	3.31	11.79	8.50	5.06	M12 x 0.71
B1021	9.37	5.67	7.50	4.00	3.75	5.98	8.82	3.50	12.37	7.22	7.06	3.50	11.91	9.03	5.47	M12 x 0.71
B1121	10.24	5.12	7.50	4.00	3.75	5.98	8.82	3.39	13.06	7.66	7.75	3.50	12.78	9.72	5.47	M16 x 0.87

Case Size	REDUCER					MOTORIZED				OUTPUT SHAFT			W-KEY		WT (LBS)
	INPUT SHAFT X Dia.	Z-KEY Y	SQ.	LG	S	56C/143/145TC J	182/184TC R Dia.	J	R Dia.	U Dia.	U1 Dia.	V	SQ.	LG	
B0521	0.625	1.31	3/16	1.00	6.19	6.71	6.50	NA	NA	1.125	1.438	2.39	1/4	1.50	32
B0621	0.625	1.31	3/16	1.00	6.60	7.12	6.50	NA	NA	1.125	1.438	2.77	1/4	1.88	37
B0821	0.750	1.48	3/16	1.13	7.75	8.80	6.50	NA	NA	1.500	1.938	2.68	3/8	1.94	65
B0921	0.750	1.48	3/16	1.13	8.13	9.18	6.50	NA	NA	1.500	2.188	3.80	3/8	2.00	72
B1021	0.750	1.48	3/16	1.13	8.45	9.59	6.50	9.87	9.00	1.500	2.188	3.83	3/8	2.25	78
B1121	0.750	1.48	3/16	1.13	8.74	9.88	6.50	10.16	9.00	1.875	2.938	4.15	1/2	2.63	98

DOUBLE REDUCTION UNIT WITH OUTPUT BRACKET

REDUCER

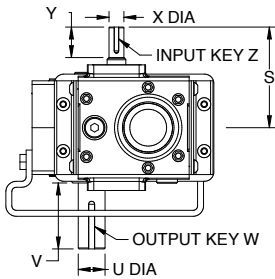

MOTORIZED

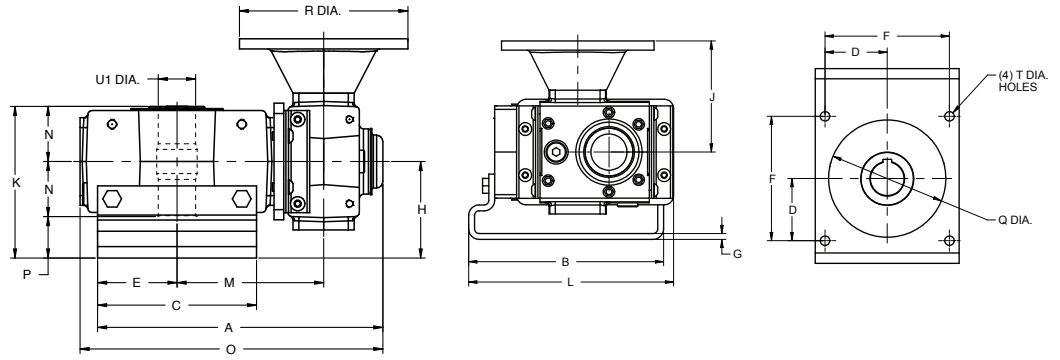

Size	A	B	C	D	E	F	G	H	K	L	M	N	O	P	Q Dia.	T Dia.
B0521	10.46	7.47	5.75	2.30	2.87	4.60	0.19	3.75	5.86	7.90	5.28	2.11	10.89	1.64	4.50	13/32
B0621	11.09	8.30	6.13	2.65	3.07	5.30	0.25	3.72	5.85	8.75	5.71	2.13	11.76	1.59	5.00	13/32
B0821	12.95	9.25	7.18	2.83	3.59	5.66	0.25	4.06	6.78	9.87	6.79	2.72	13.57	1.34	6.00	13/32
B0921	14.00	10.02	8.50	3.18	4.25	6.36	0.25	4.50	7.22	10.44	7.19	2.72	14.35	1.78	7.00	13/32
B1021	14.01	10.91	8.50	3.54	4.25	7.07	0.25	5.25	8.24	11.53	7.22	2.99	14.44	2.26	7.00	9/16
B1121	14.94	12.35	9.50	3.54	4.75	7.07	0.25	5.25	8.58	12.67	7.66	3.33	15.31	1.92	8.56	9/16

Case Size	REDUCER					MOTORIZED				OUTPUT SHAFT			W-KEY		WT (LBS)
	INPUT SHAFT	Z-KEY			S	56C/143/145TC		182/184TC		U Dia.	UI Dia.	V	SQ.	LG	
X Dia.	Y	SQ.	LG	J		R Dia.	J	R Dia.							
B0521	0.625	1.31	3/16	1.00	4.22	4.74	6.50	NA	NA	1.125	1.438	2.39	1/4	1.50	32
B0621	0.625	1.31	3/16	1.00	4.22	4.74	6.50	NA	NA	1.125	1.438	2.77	1/4	1.88	37
B0821	0.750	1.48	3/16	1.13	5.13	6.18	6.50	NA	NA	1.500	1.938	2.68	3/8	1.94	65
B0921	0.750	1.48	3/16	1.13	5.13	6.18	6.50	NA	NA	1.500	2.188	3.80	3/8	2.00	72
B1021	0.750	1.48	3/16	1.13	5.20	6.34	6.50	6.62	9.00	1.500	2.188	3.83	3/8	2.25	78
B1121	0.750	1.48	3/16	1.13	5.20	6.34	6.50	6.62	9.00	1.875	2.938	4.15	1/2	2.63	98

UNIT WITH OUTPUT BRACKET

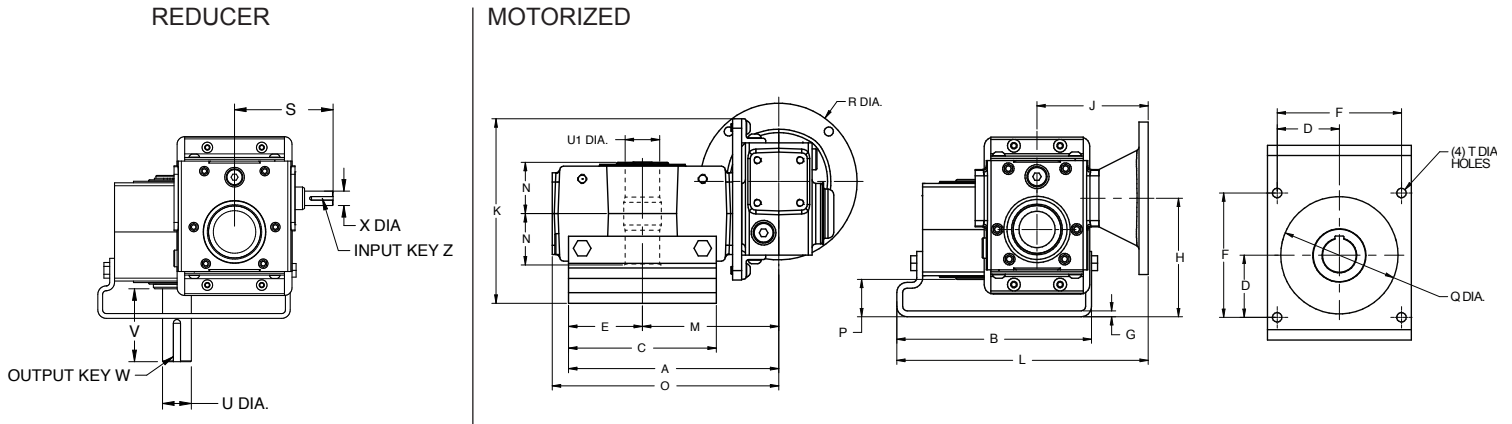

Size	A	B	C	D	E	F	G	H	K	M	N	O	P	Q Dia.	T Dia.
B0521	8.16	7.47	5.75	2.30	2.88	4.60	0.19	5.08	7.69	5.28	2.11	8.58	1.64	4.50	13/32
B0621	8.59	8.30	5.75	2.65	2.88	5.30	0.25	5.08	7.66	5.71	2.13	9.45	1.59	5.00	13/32
B0821	10.38	9.25	7.18	2.83	3.59	5.66	0.25	5.81	9.02	6.79	2.72	11.00	1.34	6.00	13/32
B0921	11.44	10.02	8.50	3.18	4.25	6.36	0.25	6.25	9.46	7.19	2.72	11.79	1.78	7.00	13/32
B1021	11.48	10.91	8.50	3.54	4.25	7.07	0.25	7.22	10.56	7.22	2.99	11.91	2.26	7.00	9/16
B1121	12.41	12.35	9.50	3.54	4.75	7.07	0.25	7.22	10.56	7.66	3.33	12.78	1.92	8.56	9/16

Case Size	REDUCER					MOTORIZED						OUTPUT SHAFT		W-KEY		WT (LBS)	
	INPUT SHAFT		Z-KEY			56C/143/145TC			182/184TC			U Dia.	U1 Dia.	V	SQ.		LG
X Dia.	Y	SQ.	LG	S	J	L	R Dia.	J	L	R Dia.	U Dia.					U1 Dia.	
B0521	0.625	1.31	3/16	1.00	4.22	4.74	9.88	6.50	NA	NA	NA	1.125	1.438	2.39	1/4	1.50	32
B0621	0.625	1.31	3/16	1.00	4.22	4.74	10.73	6.50	NA	NA	NA	1.125	1.438	2.77	1/4	1.88	37
B0821	0.750	1.48	3/16	1.13	5.13	6.18	12.74	6.50	NA	NA	NA	1.500	1.938	2.68	3/8	1.94	65
B0921	0.750	1.48	3/16	1.13	5.13	6.18	13.31	6.50	NA	NA	NA	1.500	2.188	3.80	3/8	2.00	72
B1021	0.750	1.48	3/16	1.13	5.20	6.34	14.37	6.50	6.62	14.65	9.00	1.500	2.188	3.83	3/8	2.25	78
B1121	0.750	1.48	3/16	1.13	5.20	6.34	15.51	6.50	6.62	15.79	9.00	1.875	2.938	4.15	1/2	2.63	98

STANDARD UNIT (No Base)

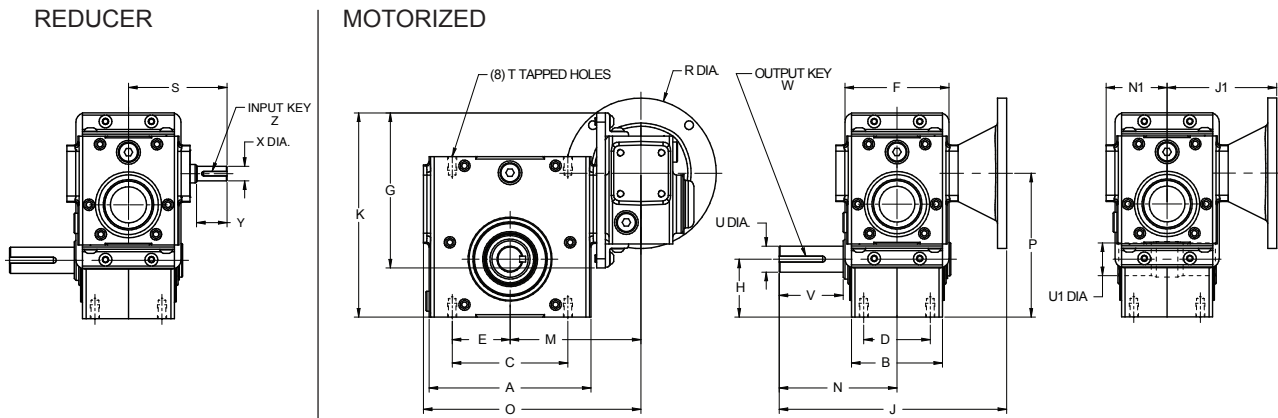

Size	A	B	C	D	E	F	G	H	K	M	N	N1	O	P	T Dia.
B0521	6.00	3.94	5.00	2.88	2.50	4.50	6.69	2.28	8.19	5.28	4.69	2.64	8.58	5.58	M10 x 0.59
B0621	7.00	3.94	5.00	2.88	2.50	4.50	6.69	2.50	8.82	5.71	5.09	2.64	9.45	6.21	M10 x 0.59
B0821	7.50	5.12	6.38	3.38	3.19	5.98	8.27	2.94	10.52	6.79	5.63	3.15	11.00	7.31	M10 x 0.59
B0921	9.00	5.12	7.00	4.00	3.50	5.98	8.27	3.25	11.21	7.19	6.75	3.15	11.79	8.00	M12 x 0.71
B1021	9.05	5.67	7.50	4.00	3.75	5.98	8.82	3.50	12.06	7.22	7.06	3.31	11.91	8.72	M12 x 0.71
B1121	9.50	5.12	7.50	4.00	3.75	5.98	8.82	3.39	12.24	7.66	7.75	3.31	12.78	8.90	M16 x 0.87

Case Size	REDUCER					MOTORIZED						OUTPUT SHAFT		W-KEY		WT (LBS)	
	INPUT SHAFT	Z-KEY				56C/143/145TC			182/184TC					SQ.	LG		
X Dia.	Y	SQ.	LG	S	J	J1	R Dia.	J	J1	R Dia.	U Dia.	U1 Dia.	V	SQ.	LG		
B0521	0.625	1.31	3/16	1.00	4.22	4.74	9.88	6.50	NA	NA	NA	1.125	1.438	2.39	1/4	1.50	32
B0621	0.625	1.31	3/16	1.00	4.22	4.74	10.73	6.50	NA	NA	NA	1.125	1.438	2.77	1/4	1.88	37
B0821	0.750	1.48	3/16	1.13	5.13	6.18	12.74	6.50	NA	NA	NA	1.500	1.938	2.68	3/8	1.94	65
B0921	0.750	1.48	3/16	1.13	5.13	6.18	13.31	6.50	NA	NA	NA	1.500	2.188	3.80	3/8	2.00	72
B1021	0.750	1.48	3/16	1.13	5.20	6.34	14.37	6.50	6.62	14.65	9.00	1.500	2.188	3.83	3/8	2.25	78
B1121	0.750	1.48	3/16	1.13	5.20	6.34	15.51	6.50	6.62	15.79	9.00	1.875	2.938	4.15	1/2	2.63	98



STANDARD UNIT (No Base)

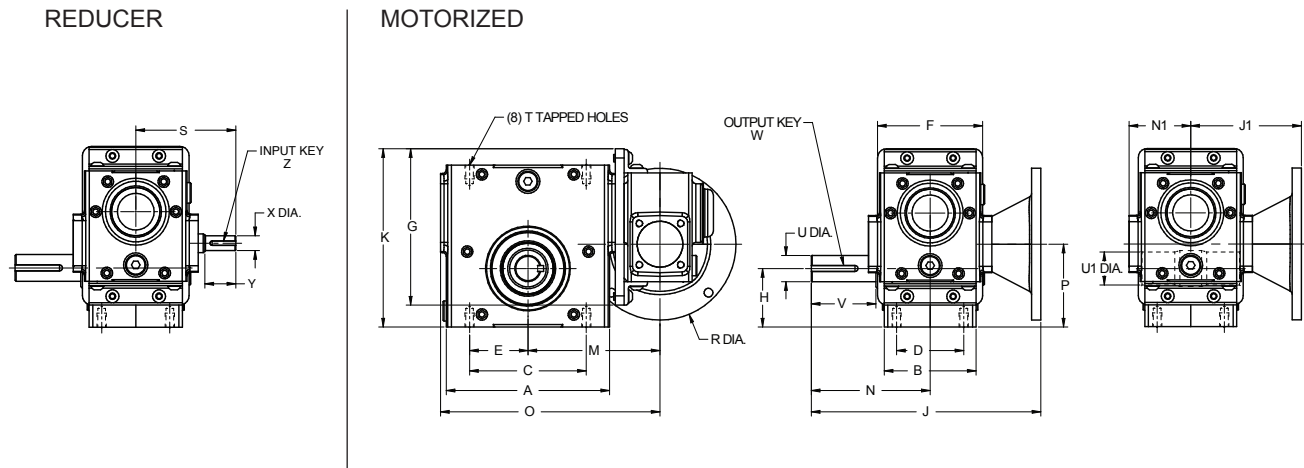

Size	A	B	C	D	E	F	G	H	K	M	N	N1	O	P	T Dia.
B0521	6.00	3.94	5.00	2.88	2.50	4.50	6.69	2.28	7.00	5.28	4.69	2.64	8.58	2.92	M10 x 0.59
B0621	7.00	3.94	5.00	2.88	2.50	4.50	6.69	2.50	7.63	5.71	5.09	2.64	9.45	3.54	M10 x 0.59
B0821	7.50	5.12	6.38	3.38	3.19	5.98	8.27	2.94	8.87	6.79	5.63	3.15	11.00	3.82	M10 x 0.59
B0921	9.00	5.12	7.00	4.00	3.50	5.98	8.27	3.25	9.56	7.19	6.75	3.15	11.79	4.50	M12 x 0.71
B1021	9.05	5.67	7.50	4.00	3.75	5.98	8.82	3.50	10.25	7.22	7.06	3.31	11.91	4.78	M12 x 0.71
B1121	9.50	5.12	7.50	4.00	3.75	5.98	8.82	3.39	10.43	7.66	7.75	3.31	12.78	4.96	M16 x 0.87

Case Size	REDUCER					MOTORIZED						OUTPUT SHAFT		W-KEY		WT (LBS)	
	INPUT SHAFT	Z-KEY				56C/143/145TC			182/184TC					SQ.	LG		
X Dia.	Y	SQ.	LG	S	J	J1	R Dia.	J	J1	R Dia.	U Dia.	U1 Dia.	V	SQ.	LG		
B0521	0.625	1.31	3/16	1.00	4.22	9.43	4.74	6.50	NA	NA	NA	1.125	1.438	2.39	1/4	1.50	32
B0621	0.625	1.31	3/16	1.00	4.22	9.83	4.74	6.50	NA	NA	NA	1.125	1.438	2.77	1/4	1.88	37
B0821	0.750	1.48	3/16	1.13	5.13	11.81	6.18	6.50	NA	NA	NA	1.500	1.938	2.68	3/8	1.94	65
B0921	0.750	1.48	3/16	1.13	5.13	12.93	6.18	6.50	NA	NA	NA	1.500	2.188	3.80	3/8	2.00	72
B1021	0.750	1.48	3/16	1.13	5.20	13.40	6.34	6.50	13.68	6.62	9.00	1.500	2.188	3.83	3/8	2.25	78
B1121	0.750	1.48	3/16	1.13	5.20	14.09	6.34	6.50	14.37	6.62	9.00	1.875	2.938	4.15	1/2	2.63	98

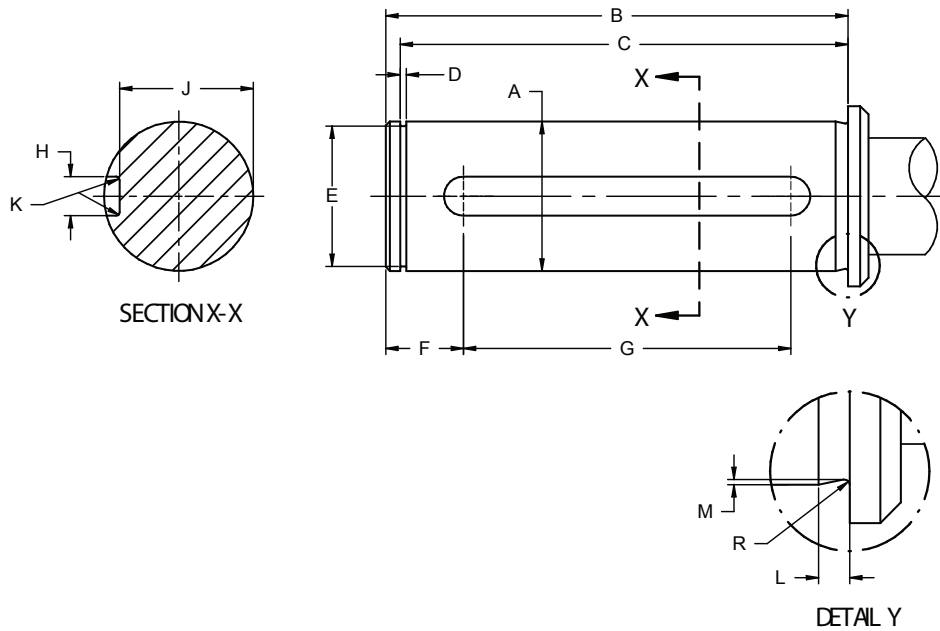

CUSTOMER SHAFT DETAIL

CASE SIZE	A	B	C	D	E	F	G	H	J	K	L	M	R
B02	1.000	4.03	3.906	0.049	0.943	0.602	3.00	0.252	0.890	0.024R	0.12	0.02	0.04
	0.999		3.902	0.046	0.937			0.250	0.884				
B03	1.000	4.42	4.299	0.049	0.943	0.800	3.00	0.252	0.890	0.024R	0.12	0.02	0.04
	0.999		4.295	0.046	0.937			0.250	0.884				
B04	1.4375	4.49	4.350	0.060	1.354	0.768	3.15	0.377	1.288	0.031R	0.12	0.02	0.04
	1.4365		4.346	0.056	1.346			0.375	1.282				
B05	1.4375	4.42	4.271	0.060	1.354	0.736	3.15	0.377	1.288	0.031R	0.12	0.02	0.04
	1.4365		4.267	0.056	1.346			0.375	1.282				
B06	1.4375	4.45	4.311	0.060	1.354	0.748	3.15	0.377	1.288	0.031R	0.12	0.02	0.04
	1.4365		4.307	0.056	1.346			0.375	1.282				
B08	1.9375	5.67	5.505	0.072	1.862	0.882	4.13	0.502	1.717	0.047R	0.12	0.02	0.04
	1.9365		5.501	0.068	1.852			0.500	1.711				
B09	2.1875	5.67	5.521	0.091	2.038	0.882	4.13	0.502	1.971	0.047R	0.12	0.02	0.04
	2.1865		5.517	0.086	2.026			0.500	1.965				
B10	2.1875	6.22	6.072	0.091	2.038	0.975	4.50	0.502	1.971	0.047R	0.12	0.02	0.04
	2.1865		6.068	0.086	2.026			0.500	1.965				
B11	2.9375	6.92	6.756	0.108	2.785	0.836	5.51	0.752	2.639	0.062R	0.12	0.02	0.04
	2.9365		6.752	0.103	2.773			0.750	2.633				

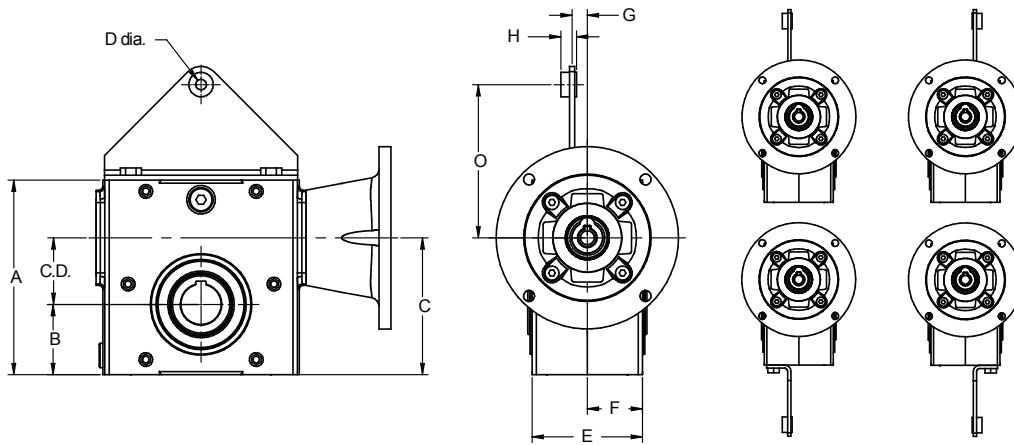

TORQUE ARM DETAILS

CASE SIZE	C.D.	A	B	C	D dia.	E	F	G	H	O
B02	1.33	4.66	1.72	3.05	0.39	2.76	1.38	0.55	0.55	3.82
B03	1.54	5.35	1.91	3.45	0.39	3.94	1.97	0.92	0.55	3.93
B04	1.75	5.75	2.06	3.81	0.39	3.94	1.97	0.82	0.55	3.82
B05	1.97	6.38	2.28	4.25	0.39	3.94	1.97	0.79	0.55	5.76
B06	2.38	6.93	2.50	4.88	0.39	3.94	1.97	0.69	0.55	5.46
B08	2.62	7.99	2.94	5.56	0.79	5.12	2.56	0.92	0.98	7.36
B09	3.00	8.88	3.25	6.25	0.79	5.12	2.56	1.19	0.98	7.25
B10	3.25	9.38	3.50	6.75	0.79	5.67	2.84	1.19	0.98	7.00
B11	3.54	9.84	3.39	6.93	0.98	5.12	2.56	1.07	0.98	9.37

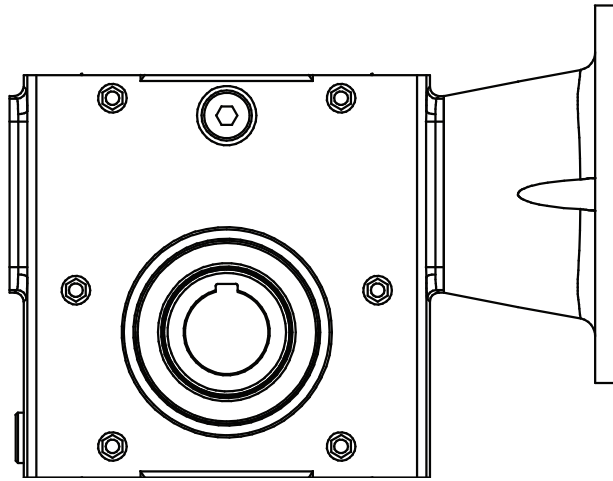
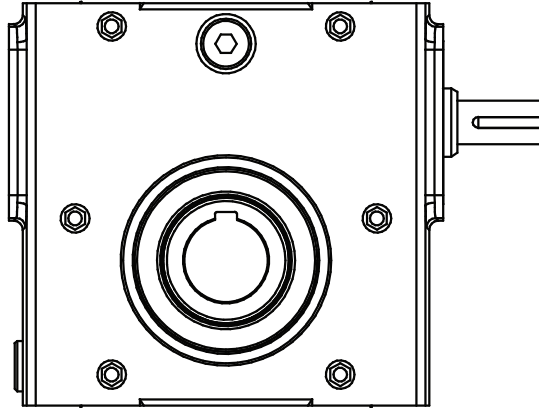

SERIES B

DIMENSIONAL COMPARISON

STANDARD UNITS

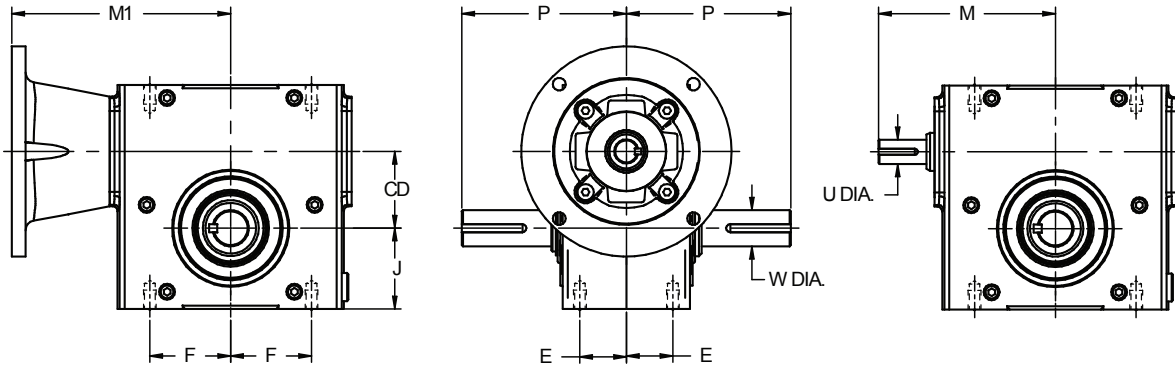

Manufacturer	Unit	CD	E	F	J	P	W Dia.	M	U Dia.	M1*
Series B	B021W/B021WM	1.33	1.00	1.63	1.72	4.00	0.625 **	4.22	0.625	4.74
Perfection-Predator	U13/UC13	1.33	1.00	1.63	1.72	4.00	0.625	3.80	0.500	3.38
Boston	F713/713	1.33	1.00	1.63	1.72	4.00	0.625	3.91	0.500	3.94
Grove - Old	BMQ1133/B1133	1.33	1.00	1.63	1.72	3.99	0.625	4.45	0.500	3.46
Grove - New	BMQ213/B213	1.33	1.00	1.63	1.72	4.00	0.625	3.82	0.500	3.46
Grove - OE	13U/13UF	1.33	1.00	1.63	1.72	4.00	0.750	3.82	0.500	3.46
Falk Omni Box	133WBM/133WB	1.33	1.00	1.63	1.72	3.99	0.625	4.45	0.500	3.46
Sterling	133BQ/133BR	1.33	1.00	1.63	1.72	3.99	0.625	4.45	0.500	3.46
Ohio	133MQ/133B	1.33	1.00	1.63	1.72	4.00	0.625	3.69	0.500	3.96
EPT - Raider	133Q/133U	1.33	1.00	1.63	1.72	4.00	0.625	4.03	0.500	3.94
Baldor	F913/S913	1.33	1.00	1.63	1.72	4.00	0.625	3.91	0.500	3.94
Leeson	B613/BMQ613	1.33	1.00	1.63	1.72	4.00	0.625	3.88	0.500	3.42
Alling Lander	13U/13UF	1.33	1.00	1.63	1.72	4.00	0.750	3.82	0.500	3.46

* for 56C frame ** Dimension shown is for the Reduced Diameter Shaft Option

Manufacturer	Unit	CD	E	F	J	P	W Dia.	M	U Dia.	M1*
Series B	B031W/B031WM	1.54	1.38	2.09	1.91	4.31	0.750	4.87	0.750	5.92
Boston	F715/715	1.54	1.38	2.09	1.91	4.31	0.750	4.69	0.625	4.50
Grove - Old	BMQ1154/B1154	1.54	1.38	2.09	1.91	4.31	0.750	4.91	0.625	3.99
Grove - New	BMQ215/B215	1.54	1.38	2.09	1.91	4.31	0.750	4.35	0.625	3.99
EPT - Raider	154Q/154U	1.54	1.38	2.09	1.91	4.31	0.750	4.69	0.625	4.52

* for a NEMA 56C frame

Manufacturer	Unit	CD	E	F	J	P	W Dia.	M	U Dia.	M1*
Series B	B041W/B041WM	1.75	1.38	2.09	2.06	4.31	0.875 **	5.13	0.750	6.18
Perfection-Predator	U18/UC18	1.75	1.38	2.09	2.06	4.31	0.875	4.75	0.625	4.04
Boston	F718/718	1.75	1.38	2.09	2.06	4.31	0.875	4.88	0.625	4.69
Grove - Old	BMQ1175/B1175	1.75	1.38	2.09	2.06	4.31	0.875	5.08	0.625	4.09
Grove - New	BMQ218/B218	1.75	1.38	2.09	2.06	4.31	0.875	4.45	0.625	4.09
Falk Omni Box	175WBM/175WB	1.75	1.38	2.09	2.06	4.31	0.875	5.08	0.625	4.09
Sterling	175AQ/175AR	1.75	1.38	2.09	2.06	4.31	0.875	5.08	0.625	4.09
Ohio	175MQ/175B	1.75	1.38	2.09	2.06	4.31	0.875	4.75	0.625	4.44
EPT - Raider	175Q/175U	1.75	1.38	2.09	2.06	4.31	0.875	4.68	0.625	4.38
Baldor	F918/S918	1.75	1.38	2.09	2.06	4.31	0.875	4.88	0.625	4.69
Leeson	B618/BMQ618	1.75	1.38	2.09	2.06	4.31	0.875	4.44	0.625	3.99
Dodge/Tigear	Q175/S175	1.75	1.38	2.09	1.99	4.31	0.875	4.75	0.625	4.94

* for 56C / 143 TC frame ** Dimension shown is for the Reduced Diameter Shaft Option

Manufacturer	Unit	CD	E	F	J	P	W Dia.	M	U Dia.	M1*
Series B	B051W/B051WM	1.97	1.44	2.50	2.28	4.69	1.000 **	5.20	0.750	6.34
Perfection-Predator	U218/UC21	2.06	1.44	2.50	2.28	4.69	1.000	5.13	0.625	4.35
Boston	F721/721	2.06	1.44	2.50	2.28	4.69	1.000	5.13	0.625	5.06
Ohio	206MQ/206B	2.06	1.44	2.50	2.28	4.69	1.000	5.16	0.625	4.75
EPT - Raider	206Q/206U	2.06	1.44	2.50	2.28	4.69	1.000	5.06	0.625	4.75
Baldor	F921/S921	2.06	1.44	2.50	2.28	4.69	1.000	4.85	0.625	4.40
Leeson	B621/BMQ621	2.06	1.44	2.50	2.28	4.68	1.000	4.85	0.625	4.40
Dodge/Tigear	Q200/S200	2.06	1.44	2.50	2.24	4.69	1.000	5.12	0.625	5.00

* for 56C/143TC frames ** Dimension shown is for the Reduced Diameter Shaft Option

STANDARD UNITS (Continued)

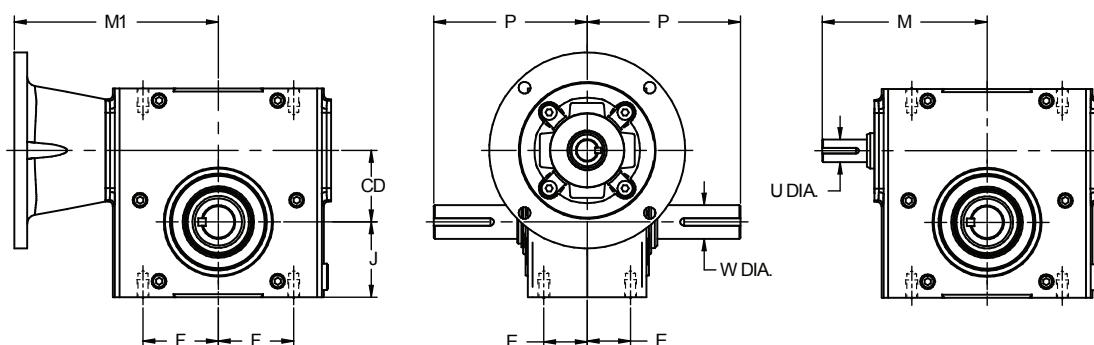

Manufacturer	Unit	CD	E	F	J	P	W Dia.	M	U Dia.	M1*
Series B	B061W/B061WM	2.38	1.44	2.50	2.50	5.09	1.125	5.47	0.750	6.77
Perfection-Predator	U214/UC24	2.38	1.44	2.50	2.50	5.09	1.125	5.75	0.750	4.75
Boston	F724/724	2.38	1.44	2.50	2.50	5.09	1.125	5.75	0.750	5.25
Grove - Old	BMQ1238/B1238	2.38	1.43	2.50	2.50	5.14	1.125	6.05	0.750	4.63
Grove - New	BMQ224/B224	2.38	1.44	2.50	2.50	5.14	1.125	5.51	0.750	4.63
Falk Omni Box	238WBM/238WB	2.38	1.43	2.50	2.50	5.14	1.125	6.05	0.750	4.63
Sterling	238AQ/238AR	2.38	1.43	2.50	2.50	5.14	1.125	6.05	0.750	4.63
Ohio	238MQ/238B	2.38	1.44	2.50	2.50	5.09	1.125	5.81	0.750	5.25
EPT - Raider	238Q/238U	2.38	1.44	2.50	2.50	5.08	1.125	5.44	0.750	5.06
Baldor	F924/S924	2.38	1.44	2.50	2.50	5.09	1.125	5.51	0.750	4.63
Leeson	B624/BMQ624	2.38	1.44	2.50	2.50	5.09	1.125	5.51	0.750	4.63

* - for 56C / 143 TC frame

Manufacturer	Unit	CD	E	F	J	P	W Dia.	M	U Dia.	M1*
Series B	B081W/B081WM	2.625	1.69	3.19	2.94	5.63	1.125 **	7.23	1.188	7.24
Perfection-Predator	U26/UC26	2.625	1.69	3.19	2.94	5.63	1.125	6.31	0.750	5.48
Boston	F726/726	2.625	1.69	3.19	2.94	5.63	1.125	6.31	0.750	5.75
Grove - Old	BMQ1262/B1262	2.625	1.69	3.19	2.94	5.63	1.250	6.57	0.750	5.19
Grove - New	BMQ226/B226	2.625	1.69	3.19	2.94	5.63	1.250	6.07	0.750	5.19
Falk Omni Box	262WBM/262WB	2.625	1.69	3.19	2.94	5.63	1.250	6.57	0.750	5.19
Sterling	262AQ/262AR	2.625	1.69	3.19	2.94	5.63	1.250	6.57	0.750	5.19
Ohio	262MQ/262B	2.625	1.69	3.19	2.94	5.63	1.125	6.31	0.750	5.62
EPT - Raider	262Q/262U	2.625	1.69	3.19	2.94	5.63	1.125	6.23	0.750	5.69
Baldor	F926/S926	2.625	1.69	3.19	2.94	5.62	1.125	6.31	0.750	5.75
Leeson	B626/BMQ626	2.625	1.69	3.19	2.94	5.63	1.125	6.12	0.750	5.23
Dodge/Tigear	262	2.625	1.69	3.19	2.88	5.63	1.125	6.32	0.750	6.63

* for 56C/143 TC frame ** Dimension shown is for the Reduced Diameter Shaft Option

Manufacturer	Unit	CD	E	F	J	P	W Dia.	M	U Dia.	M1*
Series B	B091W/B091WM	3.00	2.00	3.50	3.25	6.75	1.250 **	7.63	1.188	7.64
Grove - Old	BMQ1300/B1300	3.00	2.00	3.50	3.25	6.75	1.250	7.25	0.875	5.69
Grove - New	BMQ230/B230	3.00	2.00	3.50	3.25	6.75	1.250	6.57	0.875	5.69
Falk Omni Box	300WBM/300WB	3.00	2.00	3.50	3.25	6.75	1.250	7.25	0.875	5.69
Sterling	300AQ/300AR	3.00	2.00	3.50	3.25	6.75	1.250	7.25	0.875	5.69
Ohio	300MQ/300B	3.00	2.00	3.50	3.25	6.75	1.250	7.50	0.875	6.25
EPT - Raider	300Q/300U	3.00	2.00	3.50	3.25	6.75	1.250	7.50	0.875	6.25

* for 56C/143 TC frame ** Dimension shown is for the Reduced Diameter Shaft Option

Manufacturer	Unit	CD	E	F	J	P	W Dia.	M	U Dia.	M1*
Series B	B101W/B101WM	3.25	2.00	3.75	3.50	7.06	1.375 **	7.64	1.188	7.72
Perfection-Predator	U32/UG32	3.25	2.00	3.75	3.50	7.06	1.375	7.44	0.875	6.22
Boston	F732/732B	3.25	2.00	3.75	3.50	7.06	1.375	7.44	0.875	7.00
Grove - Old	BMQ232/B232	3.25	2.00	3.75	3.50	7.06	1.500	6.76	0.875	6.31
Grove - New	BMQ230/B230	3.25	2.00	3.75	3.50	7.06	1.500	6.76	0.875	5.88
Falk Omni Box	300WBM/300WB	3.25	2.00	3.75	3.50	7.06	1.500	6.76	0.875	6.31
Sterling	300AQ/300AR	3.25	2.00	3.75	3.50	7.06	1.500	6.76	0.875	6.31
EPT - Raider	325Q/325U	3.25	2.00	3.75	3.50	7.06	1.375	7.06	0.875	7.00
Ohio	325MQ/325B	3.25	2.00	3.75	3.50	7.06	1.375	7.19	0.875	6.47
Baldor	F932/S932	3.25	2.00	3.75	3.50	7.06	1.375	7.44	0.875	7.00
Leeson	B632/BMQ632	3.25	2.00	3.75	3.50	7.06	1.375	7.44	0.875	6.56

* for 180 frame ** Dimension shown is for the Reduced Diameter Shaft Option

STANDARD UNITS (Continued)

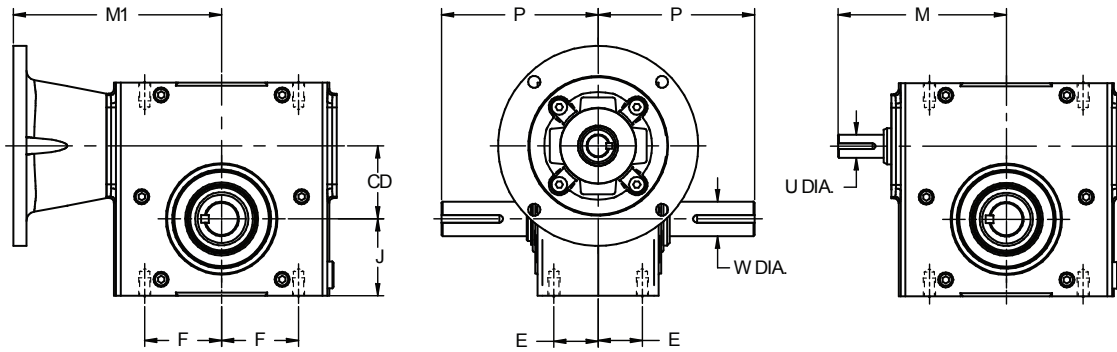

Manufacturer	Unit	CD	E	F	J	P	W Dia.	M	U Dia.	M1*
Series B	B111W/B111WM	3.54	2.00	3.75	3.39	7.75	1.625 **	8.39	1.188	8.50
Dodge/Tigear	350	3.50	2.00	3.75	4.00	7.06	1.500	7.19	0.875	7.41

* for 180 frame

** Dimension shown is for the Reduced Diameter Shaft Option

Manufacturer	Unit	CD	E	F	J	P	W Dia.	M	U Dia.	M1*
Series B	B111W/B111WM	3.54	2.00	3.75	3.39	7.75	1.625 **	8.39	1.188	8.50
Perfection-Modular	H38/HG38	3.75	1.50	3.44	3.94	6.69	1.500	7.50	1.000	6.10
Hub City	381/384	3.75	1.50	3.44	3.94	6.69	1.500	7.50	1.000	6.63
Perfection-Predator	U38/UG38	3.75	2.38	4.25	3.88	7.75	1.625	8.38	1.000	6.73
Boston	F738/S738B	3.75	2.38	4.25	3.88	7.75	1.625	8.38	1.000	7.50
EPT-Raider	375U/375Q	3.75	2.38	4.25	3.88	7.75	1.625	7.84	1.000	7.29
EPT Cobra	38U/38Q	3.75	2.38	3.38	4.50	6.81	1.625	7.84	1.000	7.25
Leeson	B638/BMQ638	3.75	2.38	4.25	3.88	7.75	1.625	8.38	1.000	7.06

* for 180 frame

** Dimension shown is for the Reduced Diameter Shaft Option

Manufacturer	Unit	CD	E	F	J	P	W Dia.	M	U Dia.	M1*
Series B	B111W/B111WM	3.54	2.00	3.75	3.39	7.75	1.875	8.39	1.188	8.50
Winsmith	943MDN/943DN	4.25	1.63	3.75	4.38	8.00	2.000	8.19	1.250	6.63
Alling-Lander	42U/42UF	4.25	1.88	3.75	4.50	7.50	1.750	9.57	1.250	7.21
Ohio	B2425/BMC2425	4.25	2.50	4.75	4.44	8.06	1.750	9.56	1.125	7.21
Grove - Old	B242/BMQ242	4.25	2.50	4.25	4.44	8.12	1.875	9.57	1.250	7.21
Grove - New	B242/BMQ242	4.25	2.50	4.25	4.44	8.12	1.875	9.57	1.250	6.45
Falk - Omni Box	425WB/425WBM	4.25	2.50	4.25	4.44	8.12	1.875	9.57	1.250	7.21
Grove - OE	42U/42UF	4.25	1.88	3.75	4.50	7.50	1.750	9.57	1.250	7.21

* for 180 frame

UNITS WITH HORIZONTAL BASE

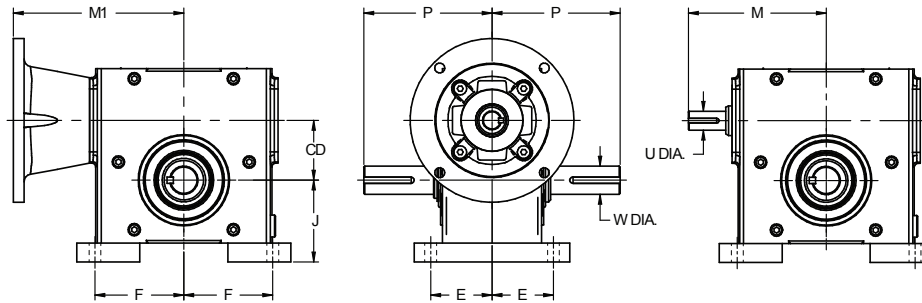

Manufacturer	Unit	CD	E	F	J	P	W Dia.	M	U Dia.	M1*
Series B	B021B/B021BM	1.33	1.66	2.19	2.25	4.00	0.625 **	4.22	0.625	4.74
Perfection-Predator	U13/UC13	1.33	1.66	2.19	2.25	4.00	0.625	3.80	0.500	3.38
Boston	F713B/713B	1.33	1.66	2.19	2.25	4.00	0.625	3.91	0.500	3.94
Grove - Old	TMQ1133/T1133	1.33	1.66	2.19	2.25	3.99	0.625	4.45	0.500	3.46
Grove - New	TMQ213/T213	1.33	1.66	2.19	2.25	4.00	0.625	3.82	0.500	3.46
Falk Omni Box	133WOMCT/133WO	1.33	1.66	2.19	2.25	3.99	0.625	4.45	0.500	3.46
Sterling	133AQ/133AR	1.33	1.66	2.19	2.25	3.99	0.625	4.45	0.500	3.46
Ohio	133MQ/133B	1.33	1.66	2.19	2.25	4.00	0.625	3.69	0.500	3.96
EPT - Raider	133QT/133UT	1.33	1.66	2.19	2.25	4.00	0.625	4.03	0.500	3.94
Baldor	F913/S913	1.33	1.66	2.19	2.25	4.00	0.625	3.91	0.500	3.94
Leeson	T613/TMQ613	1.33	1.66	2.19	2.25	4.00	0.625	3.82	0.500	3.42
Dodge/Tigear	Q133/S133	1.33	1.66	2.19	2.25	4.00	0.625	3.90	0.625	3.72

* for 56C frame ** Dimension shown is for the Reduced Diameter Shaft Option

Manufacturer	Unit	CD	E	F	J	P	W Dia.	M	U Dia.	M1*
Series B	B031B/B031BM	1.54	2.16	2.63	2.50	4.31	0.750	4.87	0.750	5.92
Boston	F715B/715B	1.54	2.16	2.63	2.50	4.31	0.750	4.69	0.625	4.50
Grove - Old	TMQ1154/T1154	1.54	2.16	2.62	2.50	4.31	0.750	4.91	0.625	3.99
Grove - New	TMQ215/T215	1.54	2.16	2.63	2.50	4.31	0.750	4.35	0.625	3.99
EPT - Raider	154QT/154UT	1.54	2.16	2.63	2.50	4.31	0.750	4.69	0.625	4.52
Dodge/Tigear	Q150/S150	1.50	2.16	2.63	2.49	4.00	0.750	5.62	0.625	4.44
Winsmith	917MDN/917DN	1.75	2.16	2.63	2.50	4.75	1.000	4.75	0.750	4.06

* for a NEMA 56C frame

Manufacturer	Unit	CD	E	F	J	P	W Dia.	M	U Dia.	M1*
Series B	B041B/B041BM	1.75	2.25	2.88	2.75	4.31	0.875 **	5.13	0.750	6.18
Perfection-Predator	U18/UC18	1.75	2.25	2.88	2.75	4.31	0.875	4.75	0.625	4.04
Boston	F718B/718B	1.75	2.25	2.88	2.75	4.31	0.875	4.88	0.625	4.69
Grove - Old	BMQ1175/B1175	1.75	2.25	2.88	2.75	4.31	0.875	5.08	0.625	4.09
Grove - New	TMQ218/T218	1.75	2.25	2.88	2.75	4.31	0.875	4.45	0.625	4.09
Falk Omni Box	175WUM/175WU	1.75	2.25	2.88	2.75	4.31	0.875	5.08	0.625	4.09
Sterling	175AQ/175AR	1.75	2.25	2.88	2.75	4.31	0.875	5.08	0.625	4.09
Ohio	175MQ/175U	1.75	2.25	2.88	2.75	4.31	0.875	4.75	0.625	4.44
EPT - Raider	175QT/175UT	1.75	2.25	2.88	2.75	4.31	0.875	4.68	0.625	4.38
Baldor	F918/S918	1.75	2.25	2.88	2.75	4.31	0.875	4.88	0.625	4.69
Leeson	T618/TMQ618	1.75	2.25	2.88	2.75	4.31	0.875	4.44	0.625	3.99
Dodge/Tigear	Q175/S175	1.75	2.25	2.88	2.75	4.31	0.875	4.75	0.625	4.94

* for 56C frame ** Dimension shown is for the Reduced Diameter Shaft Option

Manufacturer	Unit	CD	E	F	J	P	W Dia.	M	U Dia.	M1*
Series B	B051B/B051BM	1.97	2.34	3.19	3.00	4.69	1.000 **	5.20	0.750	6.34
Perfection-Predator	U21/UC21	2.06	2.34	3.19	3.00	4.69	1.000	5.13	0.625	4.35
Boston	F721B/721B	2.06	2.34	3.19	3.00	4.69	1.000	5.13	0.625	5.06
Grove - Old	TMQ1206/T1206	2.06	2.34	3.19	3.00	4.68	1.000	5.45	0.625	4.46
Grove - New	TMQ220/T220	2.06	2.34	3.19	3.00	4.68	1.000	4.82	0.625	4.46
Falk Omni Box	206WOM/206WO	2.06	2.34	3.19	3.00	4.68	1.000	5.45	0.625	4.46
Sterling	206AQ/206AR	2.06	2.34	3.19	3.00	4.68	1.000	5.45	0.625	4.46
Ohio	206MQ/206B	2.06	2.34	3.19	3.00	4.69	1.000	5.16	0.625	4.75
EPT - Raider	206QT/206UT	2.06	2.34	3.19	3.00	4.69	1.000	5.06	0.625	4.75
Baldor	F921/S921	2.06	2.34	3.19	3.00	4.69	1.000	4.85	0.625	4.40
Leeson	T621/TMQ621	2.06	2.34	3.19	3.00	4.68	1.000	4.85	0.625	4.40
Dodge/Tigear	Q200/S200	2.06	2.34	3.19	3.00	4.69	1.000	5.12	0.625	5.00

* for 56C/143TC frames ** Dimension shown is for the Reduced Diameter Shaft Option

UNITS WITH HORIZONTAL BASE (Continued)

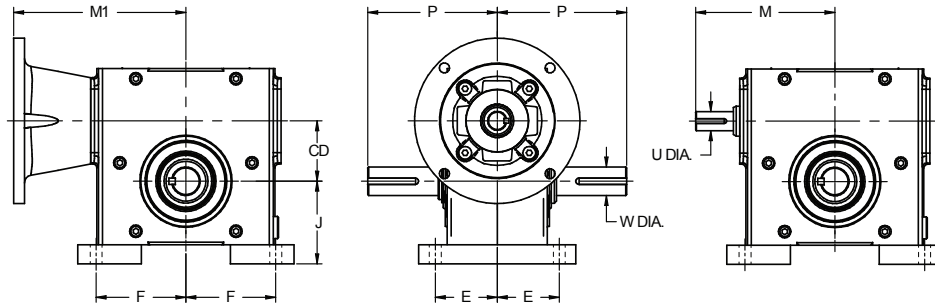

Manufacturer	Unit	CD	E	F	J	P	W Dia.	M	U Dia.	M1*
Series B	B061B/B061BM	2.38	2.44	3.53	3.25	5.09	1.125	5.47	0.750	6.77
Perfection-Predator	U24/UC24	2.38	2.44	3.53	2.50	5.09	1.125	5.75	0.750	4.75
Boston	F724B/724B	2.38	2.44	3.53	3.25	5.09	1.125	5.75	0.750	5.25
Grove - Old	TMQ1238/T1238	2.38	2.44	3.53	3.25	5.14	1.125	6.05	0.750	4.63
Grove - New	TMQ224/T224	2.38	2.44	3.53	3.25	5.14	1.125	5.51	0.750	4.63
Falk Omni Box	238WOM/238WO	2.38	2.44	3.53	3.25	5.14	1.125	6.05	0.750	4.63
Sterling	238AQ/238AR	2.38	2.44	3.53	3.25	5.14	1.125	6.05	0.750	4.63
Ohio	238MQ/238B	2.38	2.44	3.53	3.25	5.09	1.125	5.81	0.750	5.25
EPT - Raider	238Q/238U	2.38	2.44	3.53	3.25	5.08	1.125	5.44	0.750	5.06
Baldor	F924/S924	2.38	2.44	3.53	3.25	5.09	1.125	5.51	0.750	4.63
Leeson	T624/TMQ624	2.38	2.44	3.53	3.25	5.09	1.125	5.51	0.750	4.63

* for 56C/143TC frames

Manufacturer	Unit	CD	E	F	J	P	W Dia.	M	U Dia.	M1*
Series B	B081B/B081BM	2.625	2.63	4.00	3.69	5.63	1.125 **	7.23	1.188	7.24
Perfection-Predator	U26/UC26	2.625	2.63	4.00	3.69	5.63	1.125	6.31	0.750	5.48
Boston	F726B/726B	2.625	2.63	4.00	3.69	5.63	1.125	6.31	0.750	5.75
Grove - Old	TMQ1262/T1262	2.625	2.63	4.00	3.69	5.63	1.250	6.57	0.750	5.19
Grove - New	TMQ226/T226	2.625	2.63	4.00	3.69	5.63	1.250	6.07	0.750	5.19
Falk Omni Box	262WOM/262WO	2.625	2.63	4.00	3.69	5.63	1.250	6.57	0.750	5.19
Sterling	262AQ/262AR	2.625	2.63	4.00	3.69	5.63	1.250	6.57	0.750	5.19
Ohio	262MQ/262B	2.625	2.63	4.00	3.69	5.63	1.125	6.31	0.750	5.62
EPT - Raider	262QT/262UT	2.625	2.63	4.00	3.69	5.63	1.125	6.23	0.750	5.69
Baldor	F926/S926	2.625	2.63	4.00	3.69	5.62	1.125	6.31	0.750	5.75
Leeson	T626/BTQ626	2.625	2.63	4.00	3.69	5.63	1.125	6.11	0.750	5.23
Dodge/Tigear	262	2.625	2.63	4.00	3.69	5.63	1.125	6.32	0.750	6.63

* for 56C/143 TC frame ** Dimension shown is for the Reduced Diameter Shaft Option

Manufacturer	Unit	CD	E	F	J	P	W Dia.	M	U Dia.	M1*
Series B	B091B/B091BM	3.00	2.94	4.22	4.00	6.75	1.250 **	7.63	1.188	7.64
Grove - Old	TMQ1300/T1300	3.00	2.94	4.22	4.00	6.75	1.250	7.25	0.875	5.69
Grove - New	TMQ230/T230	3.00	2.94	4.22	4.00	6.75	1.250	6.57	0.875	5.69
Falk Omni Box	300WOM/300WO	3.00	2.94	4.22	4.00	6.75	1.250	7.25	0.875	5.69
Sterling	300AQ/300AR	3.00	2.94	4.22	4.00	6.75	1.250	7.25	0.875	5.69
Ohio	300MQ/300B	3.00	2.94	4.22	4.00	6.75	1.250	7.50	0.875	6.25
EPT - Raider	300QT/300UT	3.00	2.94	4.22	4.13	6.75	1.250	7.50	0.875	6.25

* for 56C/143 TC frame ** Dimension shown is for the Reduced Diameter Shaft Option

Manufacturer	Unit	CD	E	F	J	P	W Dia.	M	U Dia.	M1*
Series B	B101B/B101BM	3.25	3.06	4.75	4.38	7.06	1.375 **	7.64	1.188	7.72
Perfection-Modular	H32/HG32	3.25	3.06	4.75	4.38	5.44	1.250	6.88	0.875	5.60
Perfection-Predator	U32/UG32	3.25	3.06	4.75	4.38	7.06	1.375	7.44	0.875	6.22
Boston	F732/732B	3.25	3.06	4.75	4.38	7.06	1.375	7.44	0.875	7.00
Grove - Old	TMQ232/T232	3.25	3.06	4.75	4.38	7.06	1.500	6.76	0.875	6.31
Grove - New	TMQ230/T230	3.25	3.06	4.75	4.38	7.06	1.500	6.76	0.875	5.88
Falk Omni Box	300WOM/300WO	3.25	3.06	4.75	4.38	7.06	1.500	6.76	0.875	6.31
Sterling	300AQ/300AR	3.25	3.06	4.75	4.38	7.06	1.500	6.76	0.875	6.31
Baldor	F932/S932	3.25	3.06	4.75	4.38	7.06	1.375	7.44	0.875	7.00
Leeson	T623/TMQ632	3.25	3.06	4.75	4.38	7.06	1.375	7.44	0.875	6.56
EPT - Raider	325UT/325U	3.25	3.06	4.75	4.38	7.06	1.375	7.06	0.875	7.00
Ohio	325MQ/325U	3.25	3.06	4.75	4.38	7.06	1.375	7.19	0.875	6.47
Winsmith	930MDN/930DN	3.00	3.06	4.75	4.38	5.88	1.375	7.00	1.000	5.56

* for 180 frame **Dimension shown is for the Reduced Diameter Shaft Option

UNITS WITH HORIZONTAL BASE (Continued)

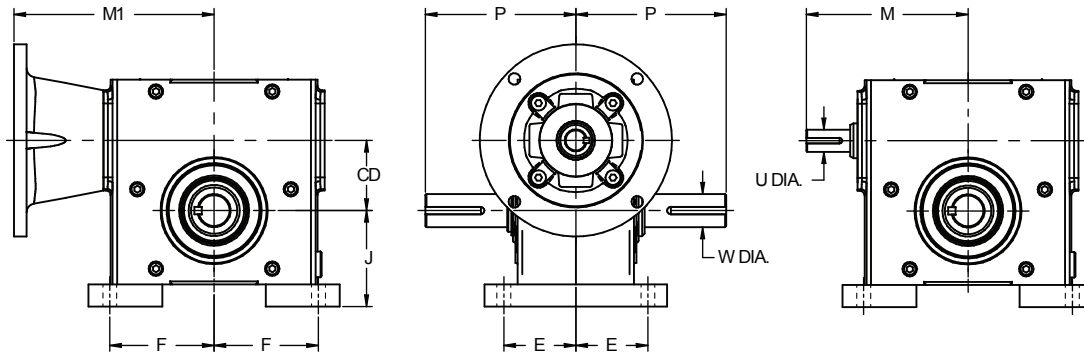

Manufacturer	Unit	CD	E	F	J	P	W Dia.	M	U Dia.	M1*
Series B	B111B/B111BM	3.54	3.06	4.75	5.00	7.75	1.625 **	8.39	1.188	8.50
Dodge/Tigear	350	3.50	3.06	4.75	5.00	7.06	1.500	7.19	0.875	7.41

* for 180 frame

** Dimension shown is for the Reduced Diameter Shaft Option

Manufacturer	Unit	CD	E	F	J	P	W Dia.	M	U Dia.	M1*
Series B	B111B/B111BM	3.54	3.06	4.75	5.00	7.75	1.625 **	8.39	1.188	8.50
Perfection-Modular	H38/HG38	3.75	3.50	5.19	4.81	6.69	1.500	7.50	1.000	6.10
Hub City	381/384	3.75	2.53	3.94	4.77	6.69	1.500	7.50	1.000	6.63
Perfection-Predator	U38/UG38	3.75	3.50	5.19	4.81	7.75	1.625	8.38	1.000	6.73
Boston	F738B/738B	3.75	3.50	5.19	4.81	7.75	1.625	8.38	1.000	7.50
EPT-Raider	375U/375Q	3.75	3.50	5.19	4.81	7.75	1.625	7.84	1.000	7.29
EPT Cobra	38U/38Q	3.75	2.38	3.38	4.50	6.81	1.625	7.84	1.000	7.25
Winsmith	935MDN/935/DN	3.50	3.50	5.19	4.81	7.00	1.750	7.38	1.000	5.81
Leeson	T638/TMQ638	3.75	3.50	5.19	4.81	7.75	1.625	8.38	1.000	7.06

* for 180 frame

** Dimension shown is for the Reduced Diameter Shaft Option

Manufacturer	Unit	CD	E	F	J	P	W Dia.	M	U Dia.	M1*
Series B	B111B/B111BM	3.54	3.06	4.75	5.00	7.75	1.875	8.39	1.188	8.50
Winsmith	943MDN/943DN	4.25	2.88	4.88	5.00	8.00	2.000	8.19	1.250	6.63
Alling-Lander	42Z/42ZF	4.25	2.88	4.88	5.00	7.50	1.750	9.57	1.250	7.21
Ohio	UMQ2425U2425	4.25	3.75	6.13	5.44	8.06	1.750	9.56	1.125	7.21
Grove - Old	T242/TMQ242	4.25	3.81	5.56	5.44	8.12	1.875	9.57	1.250	7.21
Grove - New	T242/TMQ242	4.25	3.81	5.56	5.44	8.12	1.875	9.57	1.250	6.45
Falk - Omni Box	425WB/425WBM	4.25	3.81	5.56	5.44	8.12	1.875	9.57	1.250	7.21
Grove - OE	42Z/42ZF	4.25	2.88	4.88	5.00	7.50	1.750	9.57	1.250	7.21

* for 180 frame

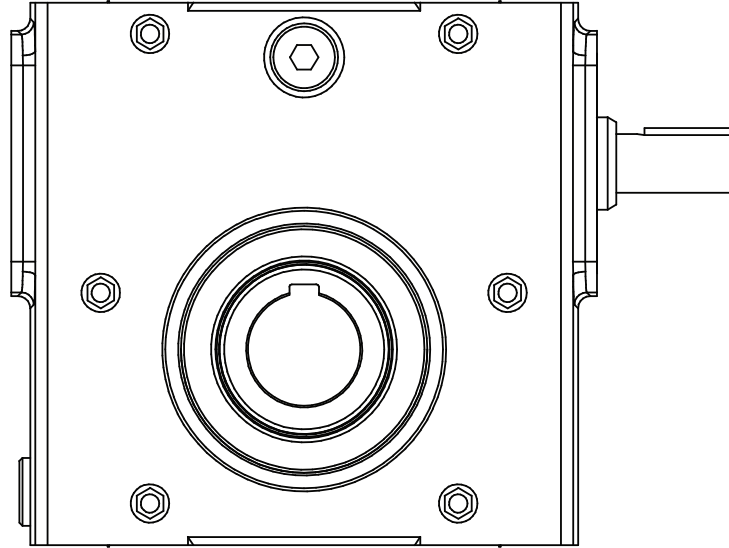

SERIES B

RATINGS



SINGLE REDUCTION - RATINGS AT 1150 RPM INPUT

RATIO:I	OUTPUT SPEED RPM	CAPACITY	SIZE OF UNIT								
			B02	B03	B04	B05	B06	B08	B09	B10	B11
5	230	Input Power, HP (mech)	1.33	1.91	2.63	3.53	5.73	7.39	10.4	12.8	15.9
		Input Power, HP (therm)	1.33	1.91	2.63	3.53	5.73	7.39	10.4	12.8	15.9
		Output Torque, lb-in (mech)	320	468	652	883	1450	1880	2670	3280	4090
		Efficiency, %	88	89	90	91	92	93	93	94	94
7.5	153	Input Power, HP (mech)	0.97	1.39	1.91	2.57	4.14	5.30	7.43	9.05	11.2
		Input Power, HP (therm)	0.97	1.39	1.91	2.57	4.14	5.30	7.43	9.05	11.2
		Output Torque, lb-in (mech)	341	499	696	944	1540	1990	2810	3440	4280
		Efficiency, %	85	87	88	89	91	91	92	92	93
10	115	Input Power, HP (mech)	0.78	0.98	1.20	1.84	2.79	3.27	4.60	6.76	8.37
		Input Power, HP (therm)	0.78	0.98	1.20	1.84	2.79	3.27	4.60	6.76	8.37
		Output Torque, lb-in (mech)	353	455	571	883	1370	1620	2290	3380	4200
		Efficiency, %	83	85	87	88	89	90	91	91	92
15	77	Input Power, HP (mech)	0.58	0.82	1.01	1.51	2.32	2.72	3.82	5.41	6.73
		Input Power, HP (therm)	0.58	0.82	1.01	1.51	2.32	2.72	3.82	5.41	6.73
		Output Torque, lb-in (mech)	369	543	684	1040	1650	1950	2760	3940	4940
		Efficiency, %	78	81	83	84	86	87	88	89	89
20	58	Input Power, HP (mech)	0.46	0.65	0.89	1.20	1.94	2.50	3.53	4.32	5.38
		Input Power, HP (therm)	0.46	0.65	0.89	1.20	1.94	2.50	3.53	4.32	5.38
		Output Torque, lb-in (mech)	360	538	763	1050	1760	2290	3290	4050	5080
		Efficiency, %	72	76	78	80	83	84	85	86	86
25	46	Input Power, HP (mech)	0.41	0.58	0.80	1.07	1.74	2.04	2.86	3.49	4.33
		Input Power, HP (therm)	0.41	0.58	0.80	1.07	1.74	2.04	2.86	3.49	4.33
		Output Torque, lb-in (mech)	383	574	818	1130	1900	2240	3200	3940	4940
		Efficiency, %	68	72	75	77	80	80	82	82	83
30	38	Input Power, HP (mech)	0.35	0.49	0.67	0.89	1.43	1.78	2.49	3.14	3.90
		Input Power, HP (therm)	0.35	0.49	0.67	0.89	1.43	1.78	2.49	3.14	3.90
		Output Torque, lb-in (mech)	373	555	786	1080	1810	2300	3270	4170	5230
		Efficiency, %	65	69	72	74	77	78	80	81	82
40	29	Input Power, HP (mech)	0.27	0.37	0.50	0.66	1.05	1.34	1.87	2.27	2.82
		Input Power, HP (therm)	0.27	0.37	0.50	0.66	1.05	1.34	1.87	2.27	2.82
		Output Torque, lb-in (mech)	333	497	705	969	1630	2120	3040	3740	4700
		Efficiency, %	56	61	64	67	71	72	74	75	76
50	23	Input Power, HP (mech)	0.24	0.32	0.42	0.55	0.86	1.09	1.51	1.83	2.25
		Input Power, HP (therm)	0.24	0.32	0.42	0.55	0.86	1.09	1.51	1.83	2.25
		Output Torque, lb-in (mech)	325	484	681	930	1540	2010	2860	3510	4390
		Efficiency, %	50	55	58	61	65	67	69	70	71
60	19	Input Power, HP (mech)	0.21	0.28	0.36	0.47	0.73	0.92	1.27	1.54	1.90
		Input Power, HP (therm)	0.21	0.28	0.36	0.47	0.73	0.92	1.27	1.54	1.90
		Output Torque, lb-in (mech)	303	450	636	872	1460	1900	2710	3340	4180
		Efficiency, %	45	50	53	56	60	62	65	66	67

NOTE: Thermal rating for units driven by fan cooled motor
 Ratings assumes units are fitted with standard output shafts

DOUBLE REDUCTION - RATINGS AT 1150 RPM INPUT

RATIO:1	OUTPUT SPEED RPM	CAPACITY	SIZE OF UNIT					
			B0521	B0621	B0821	B0921	B1021	B1121
100	12	Input Power HP (mech)	0.43	0.71	0.89	1.26	1.53	1.91
		Output Torque lb-in (mech)	1550	2600	3390	4870	6000	7540
		Full Load Efficiency, %	65	67	69	70	72	72
150	7.7	Input Power, HP (mech.)	0.31	0.51	0.63	0.89	1.08	1.34
		Output Torque, lb-in (mech.)	1550	2600	3390	4870	6000	7540
		Full Load Efficiency, %	61	62	66	66	68	68
200	5.8	Input Power, HP (mech.)	0.24	0.40	0.49	0.70	0.84	1.05
		Output Torque, lb-in (mech.)	1550	2600	3390	4870	6000	7540
		Full Load Efficiency, %	58	59	63	64	65	66
300	3.8	Input Power, HP (mech.)	0.18	0.29	0.36	0.51	0.61	0.76
		Output Torque, lb-in (mech.)	1550	2600	3390	4870	6000	7540
		Full Load Efficiency, %	53	54	58	59	60	61
400	2.9	Input Power, HP (mech.)	0.15	0.24	0.29	0.41	0.49	0.61
		Output Torque, lb-in (mech.)	1550	2600	3390	4870	6000	7540
		Full Load Efficiency, %	48	49	53	54	56	56
500	2.3	Input Power HP (mech)	0.12	0.20	0.24	0.34	0.41	0.51
		Output Torque lb-in (mech)	1550	2600	3390	4870	6000	7540
		Full Load Efficiency, %	46	47	51	52	54	54
600	1.9	Input Power, HP (mech.)	0.11	0.18	0.22	0.31	0.36	0.46
		Output Torque, lb-in (mech.)	1550	2600	3390	4870	6000	7540
		Full Load Efficiency, %	42	43	48	48	50	50
800	1.4	Input Power, HP (mech.)	0.10	0.16	0.18	0.26	0.31	0.38
		Output Torque, lb-in (mech.)	1550	2600	3390	4870	6000	7540
		Full Load Efficiency, %	36	37	42	43	45	45
1000	1.2	Input Power, HP (mech.)	0.09	0.14	0.16	0.23	0.27	0.34
		Output Torque, lb-in (mech.)	1550	2600	3390	4870	6000	7540
		Full Load Efficiency, %	32	33	38	39	41	41
1200	1.0	Input Power, HP (mech.)	0.08	0.14	0.15	0.21	0.25	0.31
		Output Torque, lb-in (mech.)	1550	2600	3390	4870	6000	7540
		Full Load Efficiency, %	28	29	34	35	37	37
1500	0.8	Input Power, HP (mech.)	0.06	0.09	0.11	0.15	0.18	0.22
		Output Torque, lb-in (mech.)	1240	2070	2700	3860	4760	5970
		Full Load Efficiency, %	27	28	31	32	33	33
1800	0.6	Input Power, HP (mech.)	0.05	0.08	0.10	0.14	0.16	0.20
		Output Torque, lb-in (mech.)	1240	2070	2700	3860	4760	5970
		Full Load Efficiency, %	24	25	28	29	30	30
2400	0.5	Input Power, HP (mech.)	0.05	0.07	0.08	0.12	0.14	0.17
		Output Torque, lb-in (mech.)	1240	2070	2700	3860	4760	5970
		Full Load Efficiency, %	21	21	25	25	27	27
3000	0.4	Input Power, HP (mech.)	0.04	0.07	0.07	0.10	0.12	0.15
		Output Torque, lb-in (mech.)	1240	2070	2700	3860	4760	5970
		Full Load Efficiency, %	18	19	22	22	24	24
3600	0.3	Input Power, HP (mech.)	0.04	0.06	0.07	0.10	0.11	0.14
		Output Torque, lb-in (mech.)	1240	2070	2700	3860	4760	5970
		Full Load Efficiency, %	16	16	20	20	22	22

NOTE: Ratings assumes units are fitted with standard output shafts

SINGLE REDUCTION - RATINGS AT 1750 RPM INPUT

RATIO:I	OUTPUT SPEED RPM	CAPACITY	SIZE OF UNIT								
			B02	B03	B04	B05	B06	B08	B09	B10	B11
5	350	Input Power, HP (mech)	1.76	2.51	3.45	4.62	7.47	9.62	13.6	16.6	20.6
		Input Power, HP (therm)	1.76	2.51	3.45	4.62	7.47	9.62	12.7	16.4	17.6
		Output Torque, lb-in (mech)	275	401	559	757	1240	1610	2280	2800	3500
		Efficiency, %	87	89	90	91	92	93	93	94	94
7.5	233	Input Power, HP (mech)	1.30	1.85	2.54	3.39	5.45	6.97	9.76	11.9	14.7
		Input Power, HP (therm)	1.30	1.85	2.54	3.39	5.45	6.97	9.76	11.9	14.2
		Output Torque, lb-in (mech)	296	433	603	818	1340	1720	2430	2970	3700
		Efficiency, %	84	86	88	89	91	92	92	93	93
10	175	Input Power, HP (mech)	1.05	1.47	1.84	2.63	4.17	4.98	6.99	8.93	11.0
		Input Power, HP (therm)	1.05	1.47	1.84	2.63	4.17	4.98	6.99	8.93	11.0
		Output Torque, lb-in (mech)	308	446	570	830	1340	1620	2290	2950	3660
		Efficiency, %	82	84	86	88	89	90	91	92	92
15	117	Input Power, HP (mech)	0.79	1.11	1.51	2.02	3.26	4.13	5.79	7.18	8.93
		Input Power, HP (therm)	0.79	1.11	1.51	2.02	3.26	4.13	5.79	7.18	8.93
		Output Torque, lb-in (mech)	325	479	674	919	1520	1950	2770	3460	4330
		Efficiency, %	76	80	82	84	87	88	89	89	90
20	88	Input Power, HP (mech)	0.62	0.88	1.20	1.60	2.59	3.34	4.70	5.74	7.15
		Input Power, HP (therm)	0.62	0.88	1.20	1.60	2.59	3.34	4.70	5.74	7.00
		Output Torque, lb-in (mech)	319	476	675	927	1550	2030	2900	3570	4480
		Efficiency, %	71	75	78	80	83	84	86	86	87
25	70	Input Power, HP (mech)	0.56	0.79	1.08	1.44	2.32	2.72	3.81	4.65	5.76
		Input Power, HP (therm)	0.56	0.79	1.08	1.44	2.32	2.72	3.81	4.65	5.71
		Output Torque, lb-in (mech)	340	510	726	1000	1680	1990	2840	3490	4370
		Efficiency, %	67	72	75	77	80	81	83	83	84
30	58	Input Power, HP (mech)	0.49	0.67	0.90	1.20	1.91	2.45	3.43	4.18	5.20
		Input Power, HP (therm)	0.49	0.67	0.90	1.20	1.91	2.45	3.43	4.18	5.20
		Output Torque, lb-in (mech)	332	494	700	961	1610	2100	3010	3700	4640
		Efficiency, %	63	68	72	74	78	79	81	82	83
40	44	Input Power, HP (mech)	0.38	0.51	0.68	0.89	1.41	1.79	2.49	3.03	3.75
		Input Power, HP (therm)	0.38	0.51	0.68	0.89	1.41	1.79	2.49	3.03	3.75
		Output Torque, lb-in (mech)	298	444	630	866	1450	1890	2710	3340	4180
		Efficiency, %	55	60	64	67	72	73	75	76	77
50	35	Input Power, HP (mech)	0.33	0.44	0.58	0.75	1.16	1.46	2.01	2.43	2.99
		Input Power, HP (therm)	0.33	0.44	0.58	0.75	1.16	1.46	2.01	2.43	2.99
		Output Torque, lb-in (mech)	291	434	610	832	1380	1790	2550	3140	3920
		Efficiency, %	49	54	58	62	66	68	70	72	73
60	29	Input Power, HP (mech)	0.29	0.38	0.50	0.64	0.98	1.24	1.70	2.05	2.52
		Input Power, HP (therm)	0.29	0.38	0.50	0.64	0.98	1.24	1.70	2.05	2.52
		Output Torque, lb-in (mech)	272	404	570	782	1300	1700	2430	2990	3740
		Efficiency, %	43	49	53	57	61	64	66	67	69

NOTE: Thermal rating for units driven by fan cooled motor
 Ratings assumes units are fitted with standard output shafts

DOUBLE REDUCTION - RATINGS AT 1750 RPM INPUT

RATIO:1	OUTPUT SPEED RPM	CAPACITY	SIZE OF UNIT					
			B0521	B0621	B0821	B0921	B1021	B1121
100	18	Input Power HP (mech)	0.59	0.98	1.23	1.73	2.10	2.61
		Output Torque lb-in (mech)	1430	2400	3130	4490	5540	6960
		Full Load Efficiency, %	67	68	71	72	73	74
150	12	Input Power, HP (mech.)	0.46	0.75	0.93	1.32	1.59	1.98
		Output Torque, lb-in (mech.)	1550	2600	3390	4870	6000	7540
		Full Load Efficiency, %	62	64	67	68	70	71
200	8.8	Input Power, HP (mech.)	0.36	0.60	0.73	1.03	1.24	1.54
		Output Torque, lb-in (mech.)	1550	2600	3390	4870	6000	7540
		Full Load Efficiency, %	59	61	65	66	67	68
300	5.8	Input Power, HP (mech.)	0.27	0.44	0.53	0.74	0.89	1.11
		Output Torque, lb-in (mech.)	1550	2600	3390	4870	6000	7540
		Full Load Efficiency, %	54	55	60	61	62	63
400	4.4	Input Power, HP (mech.)	0.22	0.36	0.43	0.60	0.72	0.89
		Output Torque, lb-in (mech.)	1550	2600	3390	4870	6000	7540
		Full Load Efficiency, %	49	50	55	56	58	59
500	3.5	Input Power HP (mech)	0.18	0.30	0.35	0.50	0.59	0.74
		Output Torque lb-in (mech)	1550	2600	3390	4870	6000	7540
		Full Load Efficiency, %	46	48	53	54	56	57
600	2.9	Input Power, HP (mech.)	0.17	0.28	0.32	0.45	0.53	0.66
		Output Torque, lb-in (mech.)	1550	2600	3390	4870	6000	7540
		Full Load Efficiency, %	43	44	49	50	52	53
800	2.2	Input Power, HP (mech.)	0.15	0.24	0.27	0.38	0.45	0.55
		Output Torque, lb-in (mech.)	1550	2600	3390	4870	6000	7540
		Full Load Efficiency, %	37	37	44	44	47	47
1000	1.8	Input Power, HP (mech.)	0.13	0.22	0.24	0.34	0.39	0.49
		Output Torque, lb-in (mech.)	1550	2600	3390	4870	6000	7540
		Full Load Efficiency, %	32	33	39	40	42	43
1200	1.5	Input Power, HP (mech.)	0.13	0.21	0.22	0.31	0.36	0.45
		Output Torque, lb-in (mech.)	1550	2600	3390	4870	6000	7540
		Full Load Efficiency, %	29	29	35	36	38	39
1500	1.2	Input Power, HP (mech.)	0.08	0.13	0.15	0.21	0.25	0.30
		Output Torque, lb-in (mech.)	1240	2070	2700	3860	4760	5970
		Full Load Efficiency, %	28	29	33	34	36	36
1800	1.0	Input Power, HP (mech.)	0.08	0.12	0.14	0.19	0.23	0.28
		Output Torque, lb-in (mech.)	1240	2070	2700	3860	4760	5970
		Full Load Efficiency, %	25	26	30	31	33	33
2400	0.7	Input Power, HP (mech.)	0.07	0.11	0.12	0.17	0.19	0.24
		Output Torque, lb-in (mech.)	1240	2070	2700	3860	4760	5970
		Full Load Efficiency, %	21	22	26	27	29	29
3000	0.6	Input Power, HP (mech.)	0.06	0.10	0.11	0.15	0.17	0.21
		Output Torque, lb-in (mech.)	1240	2070	2700	3860	4760	5970
		Full Load Efficiency, %	19	19	23	24	26	26
3600	0.5	Input Power, HP (mech.)	0.06	0.09	0.10	0.14	0.16	0.20
		Output Torque, lb-in (mech.)	1240	2070	2700	3860	4760	5970
		Full Load Efficiency, %	16	17	21	21	23	23

NOTE: Ratings assumes units are fitted with standard output shafts

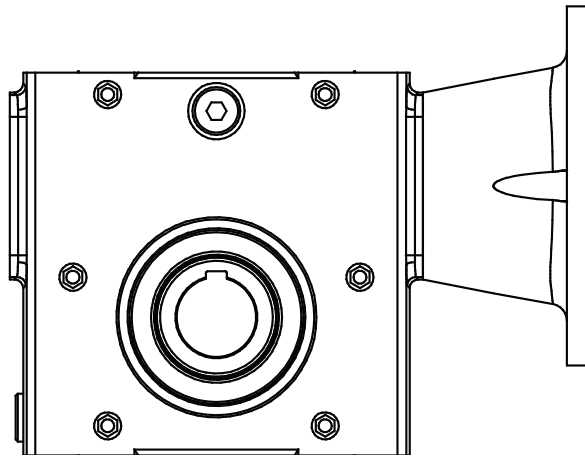
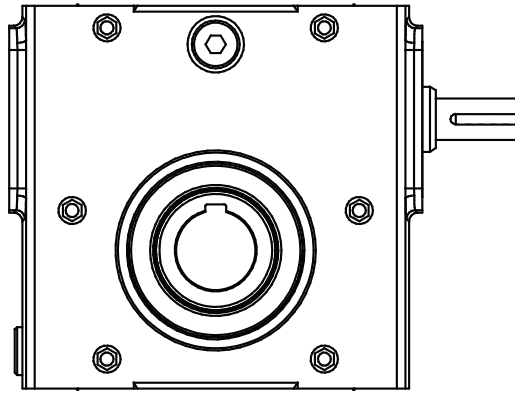

SERIES B

KIT SELECTION



	B02	B03	B04
RATIO	INCH BORE	INCH BORE	INCH BORE
5:1	B02-05-A	B03-05-A	B04-05-A
7.5:1	B02-07-A	B03-07-A	B04-07-A
10:1	B02-10-A	B03-10-A	B04-10-A
15:1	B02-15-A	B03-15-A	B04-15-A
20:1	B02-20-A	B03-20-A	B04-20-A
25:1	B02-25-A	B03-25-A	B04-25-A
30:1	B02-30-A	B03-30-A	B04-30-A
40:1	B02-40-A	B03-40-A	B04-40-A
50:1	B02-50-A	B03-50-A	B04-50-A
60:1	B02-60-A	B03-60-A	B04-60-A

	B05	B06	B08
RATIO	INCH BORE	INCH BORE	INCH BORE
5:1	B05-05-A	B06-05-A	B08-05-A
7.5:1	B05-07-A	B06-07-A	B08-07-A
10:1	B05-10-A	B06-10-A	B08-10-A
15:1	B05-15-A	B06-15-A	B08-15-A
20:1	B05-20-A	B06-20-A	B08-20-A
25:1	B05-25-A	B06-25-A	B08-25-A
30:1	B05-30-A	B06-30-A	B08-30-A
40:1	B05-40-A	B06-40-A	B08-40-A
50:1	B05-50-A	B06-50-A	B08-50-A
60:1	B05-60-A	B06-60-A	B08-60-A

	B09	B10	B11
RATIO	INCH BORE	INCH BORE	INCH BORE
5:1	B09-05-A	B10-05-A	B11-05-A
7.5:1	B09-07-A	B10-07-A	B11-07-A
10:1	B09-10-A	B10-10-A	B11-10-A
15:1	B09-15-A	B10-15-A	B11-15-A
20:1	B09-20-A	B10-20-A	B11-20-A
25:1	B09-25-A	B10-25-A	B11-25-A
30:1	B09-30-A	B10-30-A	B11-30-A
40:1	B09-40-A	B10-40-A	B11-40-A
50:1	B09-50-A	B10-50-A	B11-50-A
60:1	B09-60-A	B10-60-A	B11-60-A

NEMA C FACE MOTOR ADAPTOR KITS

Single Stage Units

MOTOR FRAME	UNIT SIZE								
	B0211	B0311	B0411	B0511	B0611	B0811	B0911	B1011	B1111
56C	U	T	T	T	T	Q	Q	Q	Q
143TC/145TC	W	V	V	V	V	R	R	R	R
182TC/184TC		X	X	X	X	T	T	T	T
213TC/215TC						V	V	V	V
Kit Number	<input type="checkbox"/> B02	<input type="checkbox"/> B03/04	<input type="checkbox"/> B03/04	<input type="checkbox"/> B05	<input type="checkbox"/> B06	<input type="checkbox"/> B08/10	<input type="checkbox"/> B08/10	<input type="checkbox"/> B08/10	<input type="checkbox"/> B11

Double Reduction Units

UNIT SIZE					
B0521	B0621	B0821	B0921	B1011	B1121
U	U	T	T	T	T
W	W	V	V	V	V
		X	X	X	X
<input type="checkbox"/> B02	<input type="checkbox"/> B02	<input type="checkbox"/> B03/04	<input type="checkbox"/> B03/04	<input type="checkbox"/> B05	<input type="checkbox"/> B05

INPUT SHAFT KITS

UNIT SIZE	INPUT SHAFT TYPE
	INCH
B02	B0210-X
B03	B03/0610-X
B04	B03/0610-X
B05	B03/0610-X
B06	B03/0610-X
B08	B08/1010-X
B09	B08/1010-X
B10	B08/1010-X
B11	B1110-X



SOLID OUTPUT SHAFT KITS

UNIT SIZE	INCH SINGLE EXTENDED	INCH DOUBLE EXTENDED
B02	B02-0N	B02-0P
B03	B03-0N	B03-0P
B04	B04-0N	B04-0P
B05	B05-0N	B05-0P
B06	B06-0N	B06-0P
B08	B08-0N	B08-0P
B09	B09-0N	B09-0P
B10	B10-0N	B10-0P
B11	B11-0N	B11-0P

UNIT SIZE	REDUCED DIAMETER OUTPUT SHAFT KITS	
	INCH SINGLE EXTENDED	INCH DOUBLE EXTENDED
B02	B02-0Q	B02- 0R
B04	B04-0Q	B04- 0R
B05	B05-0Q	B05- 0R
B08	B08-0Q	B08- 0R
B09	B09-0Q	B09- 0R
B10	B10-0Q	B10- 0R
B11	B11-0Q	B11- 0R

BOLT ON BASE KITS

UNIT SIZE	STANDARD BASE KITS		
	HORIZONTAL BASE	VERTICAL BASE (HIGH)	VERTICAL BASE (LOW)
B02	B02-BE	B02-HE	B02-LE
B03	B03-BE	B03-HE	B03-LE
B04	B04-BE	B04-HE	B04-LE
B05	B05-BE	B05-HE	B05-LE
B06	B06-BE	B06-HE	B06-LE
B08	B08-BE	B08-HE	B08-LE
B09	B09-BE	B09-HE	B09-LE
B10	B10-BE	B10-HE	B10-LE
B11	B11-BE	B11-HE	B11-LE

SHAFT MOUNT BUSHING KITS

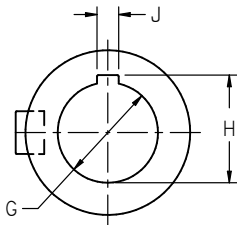

BUSHING WITH KEYWAY

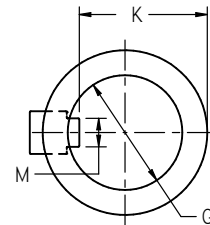
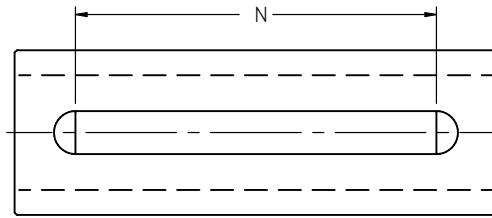

BUSHING WITH STEP KEY

UNIT SIZE	COLUMN II ENTRY	Ø C	H	I	J	K	M	N	KIT NUMBER
B02	E	.6255 ±.0005	0.685	3/16	0.189	-	-	-	B02-EB
B03	E	.6255 ±.0005	0.685	3/16	0.189	-	-	-	B03-EB
	F	.8755 ±.0005	-	-	-	0.810	3/16	3.00	B03-FB
B04	E	.8755 ±.0005	0.939	3/16	0.189	-	-	-	B04-EB
	F	1.0005 ±.0005	-	-	-	0.899	1/4	3.15	B04-FB
	G	1.1255 ±.0005	-	-	-	1.026	1/4	3.15	B04-GB
	J	1.2505 ±.0005	-	-	-	1.153	1/4	3.15	B04-JB
B05	E	1.0005 ±.0005	-	-	-	0.899	1/4	3.15	B05-EB
	F	1.1255 ±.0005	-	-	-	1.026	1/4	3.15	B05-FB
	G	1.1880 ±.0005	-	-	-	1.090	1/4	3.15	B05-GB
	J	1.2505 ±.0005	-	-	-	1.153	1/4	3.15	B05-JB
B06	E	1.0005 ±.0005	-	-	-	0.899	1/4	3.15	B06-EB
	F	1.1255 ±.0005	-	-	-	1.026	1/4	3.15	B06-FB
	G	1.1880 ±.0005	-	-	-	1.090	1/4	3.15	B06-GB
	J	1.2505 ±.0005	-	-	-	1.153	1/4	3.15	B06-JB
B08	E	1.1255 ±.0005	1.217	1/4	0.251	-	-	-	B08-EB
	J	1.4380 ±.0005	-	-	-	1.297	3/8	4.10	B08-JB
B09	E	1.4380 ±.0005	1.550	3/8	0.376	-	-	-	B09-EB
	F	1.7505 ±.0005	-	-	-	1.614	3/8	4.10	B09-FB
	G	1.9380 ±.0005	-	-	-	1.727	1/2	4.10	B09-GB
B10	E	1.4380 ±.0005	1.550	3/8	0.376	-	-	-	B10-EB
	F	1.7505 ±.0005	-	-	-	1.614	3/8	4.50	B10-FB
	G	1.9380 ±.0005	-	-	-	1.727	1/2	4.50	B10-GB
B11	E	1.4380 ±.0005	1.550	3/8	0.376	-	-	-	B11-EB
	G	2.1880 ±.0005	-	-	-	1.980	1/2	5.50	B11-GB
	J	2.4380 ±.0005	-	-	-	2.188	5/8	5.50	B11-JB



OUTPUT BRACKET & TORQUE ARM MOUNT KITS

UNIT SIZE	KIT NUMBERS	
	STANDARD OUTPUT BRACKET	STANDARD TORQUE ARM MOUNT
B02	B0210-BK	B0210-TA
B03	B0310-BK	B0310-TA
B04	B0410-BK	B0410-TA
B05	B0510-BK	B0510-TA
B06	B0610-BK	B0610-TA
B08	B0810-BK	B0810-TA
B09	B0910-BK	B0910-TA
B10	B1010-BK	B1010-TA
B11	B1110-BK	B1110-TA

DOUBLE REDUCTION UNIT SIZE BREAKDOWN

SIZE	B0521	B0621	B0821	B0921	B1021	B1121
PRIMARY	B0211	B0211	B041	B0411	B0511	B0511
SECONDARY	B0511	B0611	B0811	B0911	B1011	B1111

DOUBLE REDUCTION RATIO BREAKDOWN - TYPICAL FOR EACH SIZE

OVERALL DOUBLE REDUCTION RATIO	PRIMARY RATIO	SECONDARY RATIO
100	5	20
150	7.5	20
200	10	20
300	15	20
400	20	20
500	25	20
600	30	20
800	40	20
1000	50	20
1200	60	20
1500	25	60
1800	30	60
2400	40	60
3000	50	60
3600	60	60

DOUBLE REDUCTION UNIT MOUNTING / CONNECTING KIT

UNIT SIZE	KIT NUMBER
B0521	B02-05CON-A
B0621	B02-06CON-A
B0821	B04-09CON-A
B0921	B04-09CON-A
B1021	B05-11CON-A
B1121	B05-11CON-A



GENERAL INFORMATION

The following instructions will help you achieve a satisfactory installation of your Series B unit, ensuring the best possible conditions for a long and trouble free operation.

All units are tested and checked prior to shipment; a great deal of care is taken in packing and shipping arrangements to ensure that the unit arrives at the customer in the approved condition.

Optimum performance is best achieved by a process of gradual load increments, up to the full value, over the first 50 hours or so of their working life. During these early stages of running, sensible precautions should be taken to avoid overloads.

The gear unit operating temperature may be higher during this period of run-in. A progressive reduction in temperature may occur over many hours until the unit has reached its highest efficiency.

Mounting of Component to Input or Output Shaft

Reference shaft dimensions and tolerances in Series B Catalog

- A. Components such as gears, sprockets, couplings, etc. should not be hammered onto shafts since it may damage the shaft support bearings.
- B. The component should be pushed onto the shaft using hydraulic or hand press with the shaft supported at the opposite end.

Weather Protection of Unit

All Series B units are provided with protection against normal weather conditions. Where units are to operate in extreme conditions, or where they are to stand for long periods without running, e.g. during plant construction, Cone Drive should be notified during time of order so arrangements can be made to provide adequate protection.

Installation

Motorized and Reducers

- All sizes are factory filled with a high quality synthetic lubricant. They are "Lubricated for Life" and require no routine maintenance in service.

Lubrication

Series B units are factory filled with a high quality synthetic lubricant. They are "Lubricated for Life" and require no routine maintenance in service.

If oil is added or replaced, refer to Table 1 for a list of approved lubricants. Lubricant quantities are given in Tables 2 & 3.

TABLE 1: TYPE H POLYALPHAOLEFIN BASED SYNTHETIC LUBRICANTS

Supplier	Lubricant Range	Oil Suppliers' Corresponding Designations
Chevron-Texaco	Clarity Synthetic PMO	460 (-23)
Exxon Mobil Corporation	SHC 600 Series	634 (-34)

These lubricants are suitable for ambient temperatures of 32°F to 104°F (0°C to 40°C); outside of the ambient range, please contact Cone Drive Application Engineers

DANGER Numbers in brackets indicate recommended minimum operating temperature in °F. The unit must not run below listed temperature.

TABLE 2: LUBRICANT QUANTITIES FOR ALL MOUNTING POSITIONS

Motorized or Reducer	GEARBOX SIZE									
	UNITS	B02	B03	B04	B05	B06	B08	B09	B10	B11
Oil Capacity	QUARTS	0.14	0.26	0.34	0.45	0.58	0.96	1.48	2.00	1.70
	LITERS	0.13	0.25	0.33	0.43	0.55	0.91	1.40	1.89	1.61

TABLE 3: DOUBLE REDUCTION LUBRICANT QUANTITIES

UNITS	GEARBOX SIZE											
	B0521		B0621		B0821		B0921		B1021		B1121	
	Primary	Secondary	Primary	Secondary	Primary	Secondary	Primary	Secondary	Primary	Secondary	Primary	Secondary
QUARTS	0.14	0.6	0.14	0.8	0.34	1.25	0.34	1.8	0.45	2.60	0.45	2.21
LITERS	0.13	0.57	0.13	0.76	0.33	1.18	0.33	1.7	0.43	2.46	0.43	2.09

IMPORTANT

General - The following information is important in ensuring safety. It **must** be brought to the attention of personnel involved in the selection of power transmission equipment, those responsible for the design of the machinery in which it is to be incorporated and those involved in its installation, use and maintenance.

Our power transmission equipment will operate safely provided it is selected, installed, used and maintained properly. As with any power transmission equipment **proper precautions must** be taken as indicated in the following paragraphs, to ensure safety.

Potential Hazards - these are **not** necessarily listed in any order of severity as the degree of danger varies in individual circumstances. It is important therefore that the list is studied in its entirety:-

- 1) Fire/Explosion
 - (a) Oil mists and vapor are generated within gear units. It is therefore dangerous to use naked lights in the proximity of gearbox openings, due to the risk of fire or explosion.
 - (b) In the event of fire or serious overheating (over 570 °F (300 °C)), certain materials (rubber, plastics, etc.) may decompose and produce fumes. Care should be taken to avoid exposure to the fumes, and the remains of burned or overheated plastic/rubber materials should be handled with rubber gloves.
- 2) Guards - Rotating shafts and couplings must be guarded to eliminate the possibility of physical contact or entanglement of clothing. It should be of rigid construction and firmly secured.
- 3) Noise - High speed gearboxes and gearbox driven machinery may produce noise levels which are damaging to the hearing with prolonged exposure. Ear defenders should be provided for personnel in these circumstances. Reference should be made to state and federal regulations for reducing exposure of employed persons to noise.
- 4) Lifting - Where provided (on larger units) only the lifting points or eyebolts must be used for lifting operations (see maintenance manual or general arrangement drawing for lifting point positions). Failure to use the lifting points provided may result in personal injury and/or damage to the product or surrounding equipment. Keep clear of raised equipment.
- 5) Lubricants and Lubrication
 - (a) Prolonged contact with lubricants can be detrimental to the skin. The manufacturer's instruction must be followed when handling lubricants.
 - (b) The lubrication status of the equipment must be checked before commissioning. Read and carry out all instructions on the lubricant plate and in the installation and maintenance literature. Heed all warning tags. Failure to do so could result in mechanical damage and in extreme cases risk of injury to personnel.
- 6) Electrical Equipment - Observe hazard warnings on electrical equipment and isolate power before working on the gearbox or associated equipment, in order to prevent the machinery being started.
- 7) Installation, Maintenance and Storage
 - (a) In the event that equipment is to be held in storage, for a period exceeding 6 months, prior to installation or commissioning, we must be consulted regarding special preservation requirements. Unless otherwise agreed, equipment must be stored in a building protected from extremes of temperature and humidity to prevent deterioration.
The rotating components (gears and shafts) must be turned a few revolutions once a month (to prevent bearings brinelling).
 - (b) External gearbox components may be supplied with preservative materials applied, in the form of a "waxed" tape overwrap or wax film preservative. Gloves should be worn when removing these materials. The former can be removed manually, the latter using white spirit as a solvent.
Preservatives applied to the internal parts of the gear units do not require removal prior to operation.
 - (c) Installation must be performed in accordance with the manufacturer's instructions and be undertaken by suitably qualified personnel.
 - (d) Before working on a gearbox or associated equipment, ensure that the load has been removed from the system to eliminate the possibility of any movement of the machinery and isolate power supply. Where necessary, provide mechanical means to ensure the machinery cannot move or rotate. Ensure removal of such devices after work is complete.
 - (e) Ensure the proper maintenance of gearboxes in operation. Use only the correct tools and our approved spare parts for repair and maintenance. Consult the Maintenance Manual before dismantling or performing maintenance work.
- 8) Hot Surfaces and Lubricants
 - (a) During operation, gear units may become sufficiently hot to cause skin burns. Care must be taken to avoid accidental contact.
 - (b) After extended running the lubricant in gear units and lubrication systems may reach temperatures sufficient to cause burns. Allow equipment to cool before servicing or performing adjustments.
- 9) Selection and Design
 - (a) Where gear units provide a backstop facility, ensure that back-up systems are provided if failure of the backstop device would endanger personnel or result in damage.
 - (b) The driving and driven equipment must be correctly selected to ensure that the complete machinery installation will perform satisfactorily, avoiding system critical speeds, system torsional vibration, etc.
 - (c) The equipment must not be operated in an environment or at speeds, powers, torques or with external loads beyond those for which it was designed.
 - (d) As improvements in design are being made continually the contents of this catalog are not to be regarded as binding in detail, and drawings and capacities are subject to alterations without notice.

The above guidance is based on the current state of knowledge and our best assessment of the potential hazards in the operation of the gear units.

Any further information or clarification required may be obtained by contacting our Application Engineers.



GLOBAL LOCATIONS

NORTH AMERICA | EUROPE | ASIA

